

SPECIFICATION



YMFG-G12832H-1DPSWSN

September 9, 2008

Version 1.01



CONTENTS

| | | |
|-----|---|----|
| 1. | GERENAL SPECIFICATIONS | 1 |
| 2. | FEATURES | 1 |
| 3. | MACHANICAL SPECIFICATIONS | 2 |
| 4. | ABSOLUTE MAXIMUM RATINGS | 2 |
| 5. | ELECTRICAL CHARACTERISTICS | 2 |
| 6. | OPTICAL CHARACTERISTICS | 3 |
| 7. | TIMING CHARACTERISTICS | 4 |
| 8. | PIN ASSIGNMENT | 6 |
| 9. | BLOCK DIAGRAM | 7 |
| 10. | OUTLINE DIMENSIONS | 8 |
| 11. | RELIABILITY | 8 |
| 12. | QUALITY GUARANTEE | 9 |
| 13. | INSPECTION CRITERIA | 10 |
| 14. | PRECAUTIONS FOR USING LCD MODULES | 13 |
| 15. | PRECAUTION FOR USING LCD MODULE | 14 |



1. GENERAL SPECIFICATIONS :

1-1 SCOPE:

This specification covers the delivery requirements for the liquid crystal display delivered by YAOYU TECHNOLOGY to Customer °

1-2 PRODUCTS:

Liquid Crystal Display Module (LCM)

1-3 MODULE NAME:

YMFG-G12832H-1DPSWSN

2. FEATURES :

| Item | Standard Value |
|-------------------|--|
| Display Type | 128 *32 dots |
| LCD Type | <input type="checkbox"/> FSTN, BLUE, Transmissive, Negative, Extended TEMP <input checked="" type="checkbox"/> FSTN, Transflective, Positive, Extended TEMP <input type="checkbox"/> STN, BLUE, Transmissive, Negative, Extended TEMP <input type="checkbox"/> STN, GREY, Transflective, Positive, Extended TEMP <input type="checkbox"/> STN, Yellow-GREEN, Positive, Normal TEMP |
| Drive Pattern | 1/33Duty, 1/6Bias |
| Viewing Direction | 6 O'clock |
| Backlight Type | <input type="checkbox"/> YELLOW-GREEN LED BOTTOM BL <input type="checkbox"/> BLUE EDGE LED BL <input type="checkbox"/> CCFL WHITE BL <input checked="" type="checkbox"/> LED WHITE BL |
| Weight | TBD |
| Interface | 8-bit 6800/Serial MPU interface |
| Driver IC | ST7565S |

3. MACHANICAL SPECIFICATIONS :

| ITEM | STANDARD VALUE | UNIT |
|------------------------|-------------------------------|------|
| DISPLAY FORMAT | 128X 32 DOTS | |
| MODULE DIMENSION | 34.5(W) X 42.5(H) X 1.7(T)MAX | mm |
| EFFECTTVE DISPLAY AREA | 32.0(W) X10.0(H) | mm |
| DOT SIZE | 0.19(W) X 0.21(H) | mm |
| DOT PITCH | 0.21(W) X 0.24 (H) | mm |
| LCD TYPE | FSTN | |
| DUTY AND BIAS | 1/33DUTY; 1/6 BIAS | |
| VIEWING DIRECTION | 6:00 | |
| BACK LIGHT | LED WHITE BL | |

4. ABSOLUTE MAXIMUM RATING

| ITEM | SYMBOL | CONDITION | STANDARD VALUE | | | UNIT |
|----------------------------|----------------|-----------|----------------|-----|------|------|
| | | | MIN | TYP | MAX | |
| POWER SUPPLY FOR LOGIC | VSS | Ta=25℃ | -5.5 | — | -2.0 | V |
| INPUT VOLTAGE | VIN | Ta=25℃ | -0.3toVdd | — | +0.3 | V |
| MODULE OPERATION TEMPATURE | TOPR | --- | -10 | — | +60 | ℃ |
| MODULE STORAGE TEMPERATURE | TSTG | --- | -20 | — | +70 | ℃ |
| STORAGE HUMIDITY | H _D | Ta < 40 ℃ | - | | 90 | %RH |

5. ELECTRICAL CHARACTERISTICS

| ITEM | SYMBOL | CONDITION | MIN | TYP | MAX | UNIT |
|------------------------|---------|--------------|-----------|-----|-----|------|
| Supply Voltage (logic) | Vdd-Vss | - | 1.8 | - | 3.3 | V |
| Supply Voltage (LCD) | Vlcd | Vdd=3.3(25℃) | 4.0 | - | 13 | V |
| Input signal voltage | V-ih | “H” level | -0.3toVdd | - | 0.3 | V |
| | V-il | “L” level | - | - | - | V |
| Output signal voltage | V-oh | “H” level | -0.3toVdd | - | 0.3 | V |
| | V-ol | “L” level | - | - | - | V |
| Supply Current (logic) | Icc | - | 0.07 | - | 0.1 | mA |
| Supply Current (LCD) | Io | - | - | - | - | mA |
| Supply Voltage (LED) | V-bl | See note 1 | | | | V |
| Supply Current (LED) | I-bl | See note 1 | | - | | mA |

Note 1: We have set some resistors between the backlight and the backlight power supply “A”.

6. OPTICAL CHARACTERISTICS

(1) DEFINITION OF VIEWING ANGLE

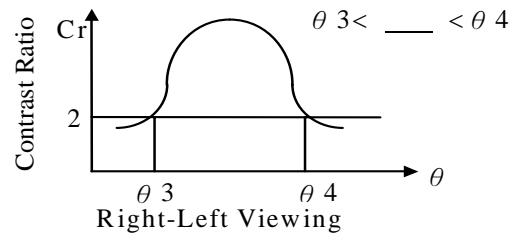
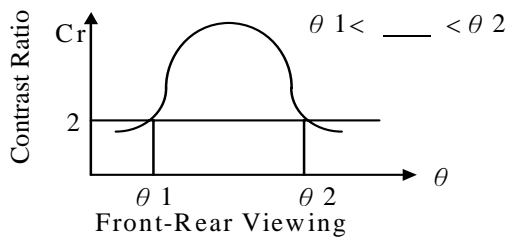
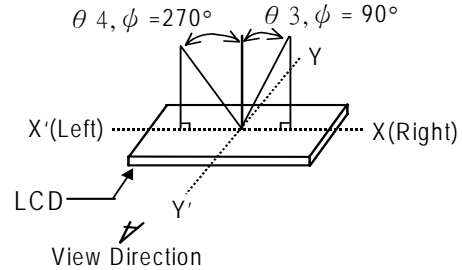
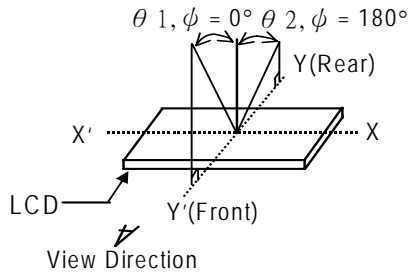

(2) DEFINITION OF CONTRAST

$$C.R = \frac{\text{Brightness of non-selected segment (B2)}}{\text{Brightness of selected segment (B1)}}$$

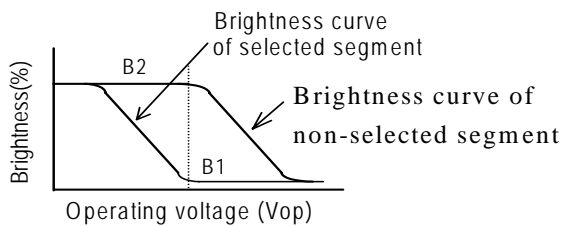

(3) DEFINITION OF RESPONSE

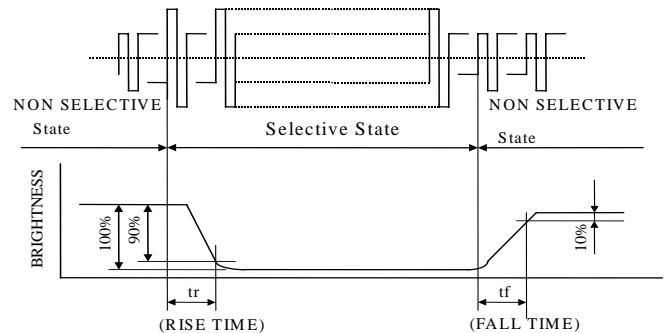

(4) Measuring Instruments For Electro-optical Characteristics

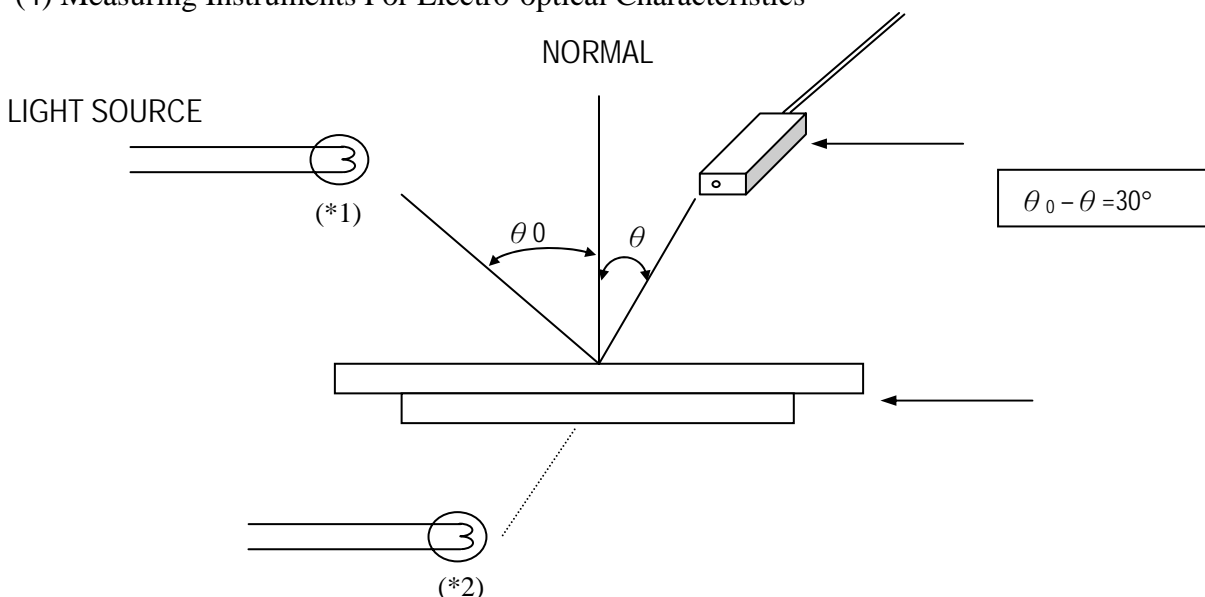



7. TIMING CHARACTERISTICS

System Bus Read/Write characters (For the 6800 Series MPU)

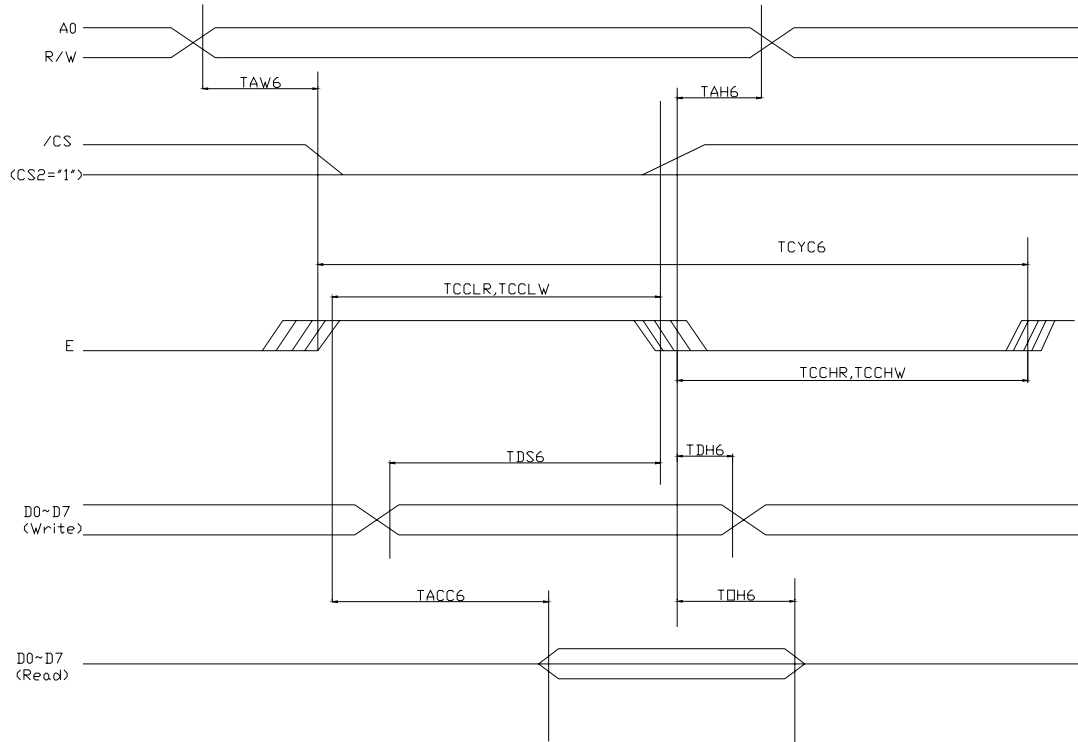

(VDD=3.3V, Ta=25°C)

| ITEM | Signal | Symbol | Condition | Rating | | Units |
|------------------------------|----------|------------|-------------|--------|------|-------|
| | | | | Min. | Max. | |
| Address hold time | A0 | t_{AH6} | | 0 | - | ns |
| Address setup time | | t_{AW6} | | 0 | - | |
| System cycle time | | t_{CYC6} | | 240 | - | |
| Enable L pulse width (WRITE) | WR | t_{EWLW} | | 80 | - | |
| Enable H pulse width (WRITE) | | t_{EWHR} | | 80 | - | |
| Enable L pulse width (READ) | RD | t_{EWLR} | | 80 | - | |
| Enable H pulse width (READ) | | t_{EWHR} | | 140 | - | |
| WRITE Data setup time | D0 to D7 | t_{DS6} | | 40 | - | |
| WRITE Address hold time | | t_{DH6} | | 0 | - | |
| READ access time | | t_{ACC6} | $C_L=100pF$ | - | 70 | |
| READ Output disable time | | t_{OH6} | $C_L=100pF$ | 5 | 50 | |



The Serial Interface

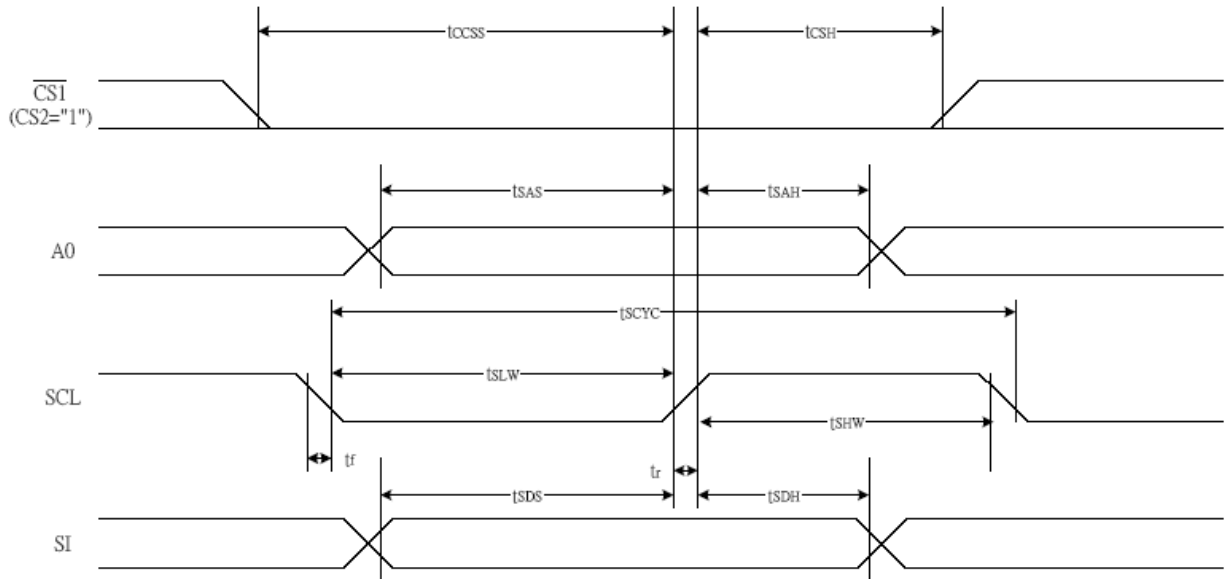

Figure 39

Table 30

(VDD = 3.3V, Ta = 25°C)

| Item | Signal | Symbol | Condition | Rating | | Units |
|---------------------|--------|------------|-----------|--------|------|-------|
| | | | | Min. | Max. | |
| Serial Clock Period | SCL | T_{scyc} | | 50 | — | ns |
| SCL "H" pulse width | | T_{shw} | | 25 | — | |
| SCL "L" pulse width | | T_{slw} | | 25 | — | |
| Address setup time | A0 | T_{sas} | | 20 | — | |
| Address hold time | | T_{sah} | | 10 | — | |
| Data setup time | SI | T_{sds} | | 20 | — | |
| Data hold time | | T_{sdh} | | 10 | — | |
| CS-SCL time | CS | T_{css} | | 20 | — | |
| CS-SCL time | | T_{csh} | | 40 | — | |

8. PIN ASSIGNMENT

| PIN | SYMBOL | FUNCTION |
|------------|---------------|---|
| 1 | VDD | Logic Voltage supply +3.3v |
| 2 | P/S | This is the MPU interface switch terminal. P/S="H":Parallel data input; P/S="L":Serial data input |
| 3 | VSS | Power Groud |
| 4~8 | V5~V1 | These are the LCD driving voltage levels. All theseLevels are referenced to VDD |
| 9 | CAP2+ | DC/DC voltage converter.A capapcitor is connected between this terminal and the CAP2- terminal. |
| 10 | CAP2- | DC/DC voltage converter.A capapcitor is connected between this terminal and the CAP2+ terminal. |
| 11 | CAP1- | DC/DC voltage converter.A capapcitor is connected between this terminal and the CAP1+ terminal. |
| 12 | CAP1+ | DC/DC voltage converter.A capapcitor is connected between this terminal and the CAP1- terminal. |
| 13 | CAP3- | DC/DC voltage converter.A capapcitor is connected between this terminal and the C1+ terminal. |
| 14 | VOUT | DC/DC voltage converter.A capapcitor is connected between this terminal and VSS. |
| 15 | VSS | Power Groud |
| 16~23 | D7~D0 | This is an 8-bit bi-directional data bus that connects to an 8-bit or 16-bit standard MPU data bus. When the serial interface is selected(p/s="L"): D7:serial data input(SI);D6:the serial clock input(SCL). D0 to D5 are set to high impedance. |
| 24 | RD(E) | ST7565S series data bus is in an output status when this signal is"L". When connected to a 6800 Series MPU,this is active HIGH. This is the 6800 Series MPU enable clock input terminal. |
| 25 | WR(R/W) | When is the read/write control signal input terminal. Wher R/W="H":Read; Wher R/W="L":Write |
| 26 | A0 | A0="H":Indicates D7~D0 is display data. A0="L": Indicates D7~D0 is control data. |
| 27 | /RET | When /RES is set to "L",the settings are initialized |
| 28 | /CS1 | This is the chip select signal. |

9. BLOCK DIAGRAM

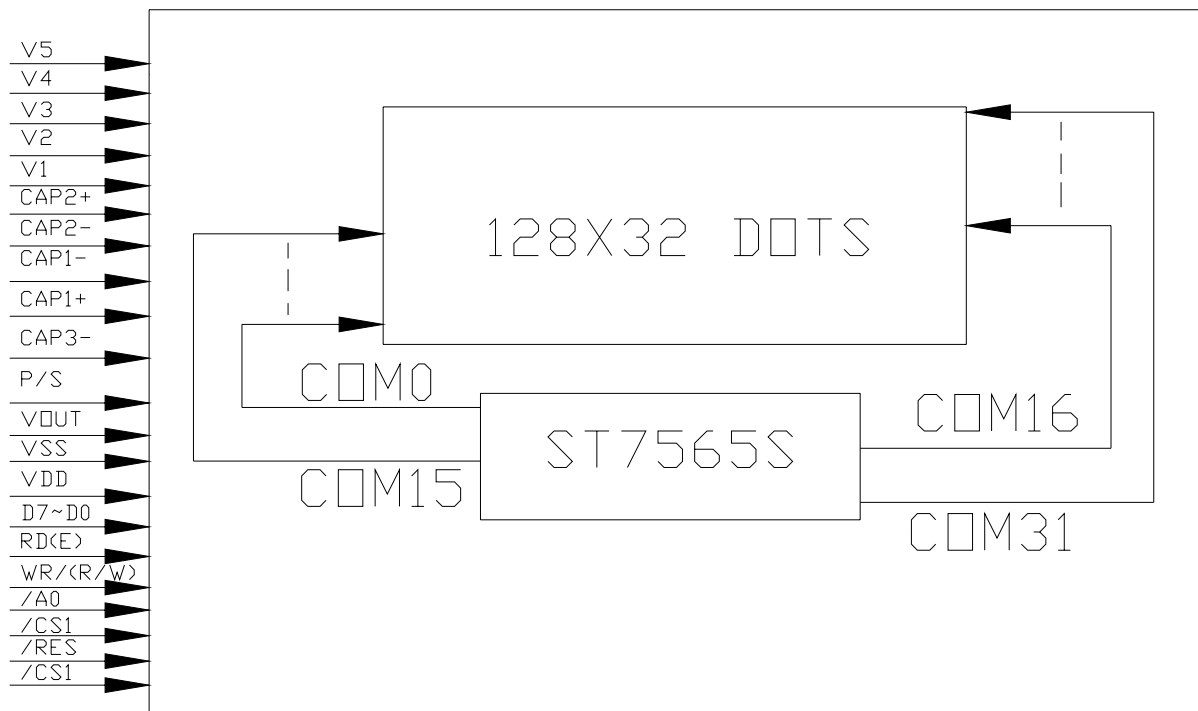

Display Control Instruction:

Please refer to the series of ST7565S.



10. OUTLINE DIMENSIONS

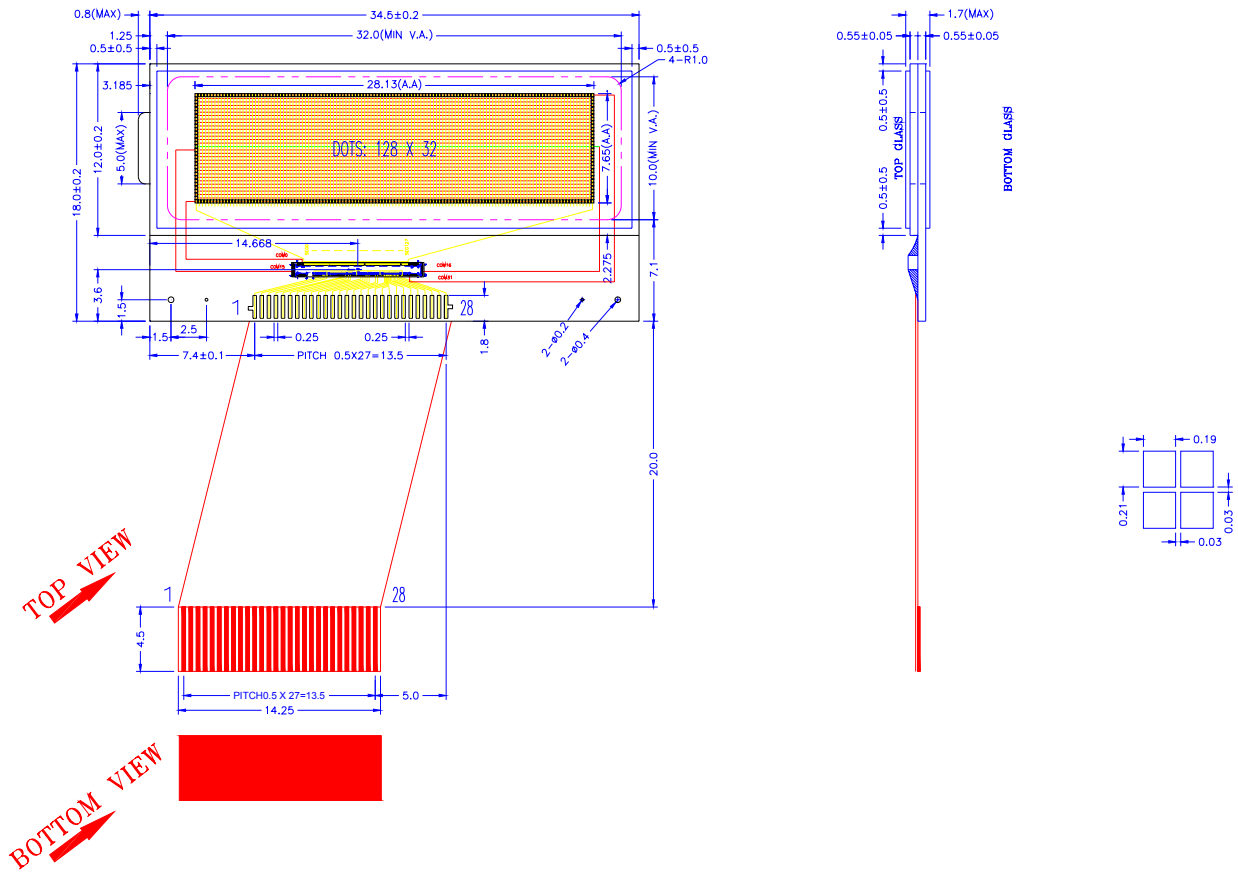

11. RELIABILITY

Content of Reliability Test

| Environmental Test | | | | |
|--------------------|----------------------------|--|-------------------|---------------------|
| No. | Test Item | Content of Test | Test Condition | Applicable Standard |
| 1 | High temperature storage | Endurance test applying the high storage temperature for a long time. | 70 °C 200 hrs | |
| 2 | Low temperature storage | Endurance test applying the low storage temperature for a long time. | -20 °C 200 hrs | |
| 3 | High temperature operation | Endurance test applying the electric stress (Voltage & Current) and the thermal stress to the element for a long time. | 60 °C 200 hrs | |
| 4 | Low temperature operation | Endurance test applying the electric stress under low temperature for a long time. | -10 °C 200 hrs | |

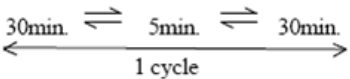
| | | | | |
|---|-------------------------------------|---|--------------------------|----------------------------|
| 5 | High temperature Humidity storage | Endurance test applying the high temperature and high humidity storage for a long time. | 50 °C , 90% RH 96 hrs | MIL-202E-103B JIS-C5023 |
| 6 | High temperature Humidity operation | Endurance test applying the electric stress (Voltage & Current) and temperature humidity stress to the element for a long time. | 50 °C , 90% RH 96 hrs | MIL-202E-103B JIS-C5023 |
| 7 | Temperature cycle | Endurance test applying the low and high temperature cycle. -10°C 25°C 60°C  | -10°C - 60°C 10 cycles | |

Mechanical Test

| | | | | |
|----|---------------------------|--|---|--|
| 8 | Vibration test | Endurance test applying the vibration during transportation and using. | 10-22Hz → 1.5mmp-p 22-500Hz → 1.5G Total 0.5hrs | MIL-202E-201A JIS-C5025 JIS-C7022-A-10 |
| 9 | Shock test | Constructional and mechanical endurance test applying the shock during transportation. | 50G half sign wave 11 msedc 3 times of each direction | MIL-202E-213B |
| 10 | Atmospheric pressure test | Endurance test applying the atmospheric pressure during transportation by air. | 115 mbar 40 hrs | MIL-202E-105C |

Others

| | | | | |
|----|-------------------------|--|---|-----------------|
| 11 | Static electricity test | Endurance test applying the electric stress to the terminal. | VS=800V, RS=1.5 k CS=100 pF 1 time | MIL-883B-3015.1 |
|----|-------------------------|--|---|-----------------|

Supply voltage for logic system = 3V. Supply voltage for LCD system = Operating voltage at 25°C.

12. QUALITY GUARANTEE

Acceptable Quality Level

Each lot should satisfy the quality level defined as follows.

- Inspection method : MIL-STD-105E LEVEL II Normal one time sampling

- AQL

| Partition | AQL | Definition |
|-----------|------|--|
| A: Major | 0.4% | Functional defective as product |
| B: Minor | 1.5% | Satisfy all functions as product but not satisfy cosmetic standard |

Definition of 'LOT'

One lot means the delivery quantity to customer at one time.

Conditions of Cosmetic Inspection

Environmental condition

The inspection should be performed at the 1cm of height from the LCD module under 2 pieces of 40W white fluorescent lamps (Normal temperature 20~25°C and normal humidity 60 ± 15%RH).

Inspection method

The visual check should be performed vertically at more than 30cm distance from the LCD panel.



Driving voltage

The VO value which the most optimal contrast can be obtained near the specified VO in the specification. (Within ± 0.5V of typical value at 25°C.).

13. INSPECTION CRITERIA

13.1 Module Cosmetic Criteria

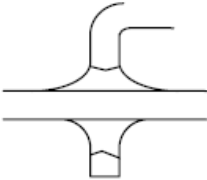
| No. | Item | Judgment Criterion | Partition |
|-----|--------------------------------------|--|----------------------|
| 1 | Difference in Spec. | None allowed | Major |
| 2 | Pattern peeling | No substrate pattern peeling and floating | Major |
| 3 | Soldering defects | No soldering missing No soldering bridge No cold soldering | Major Major Major |
| 4 | Resist flaw on substrate | Invisible copper foil (0.5mm or more) on substrate pattern | Minor |
| 5 | Accretion of metallic Foreign matter | No soldering dust No accretion of metallic foreign matters (Not exceed 0.2mm) | Minor Minor |
| 6 | Stain | No stain to spoil cosmetic badly | Minor |
| 7 | Plate discoloring | No plate fading, rusting and discoloring | Minor |
| 8 | Solder amount | a. Soldering side of PCB Solder to form a 'Filet' all around the lead. Solder should not hide the lead form perfectly. (too much) b. Components side | Minor |

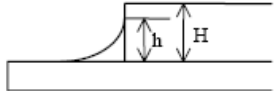
| | | | |
|------------------|---|--|-------|
| | (In case of 'Through Hole PCB') Solder to reach the Components side of PCB. |  | |
| 2. Flat packages | Either 'Toe' (A) or 'Seal' (B) of the lead to be covered by 'Filet'. Lead form to be assume over solder. A B |  | Minor |
| 3. Chips | $(3/2) H \geq h \geq (1/2) H$ |  | Minor |

13.2 Screen Cosmetic Criteria (Non-Operating)

| No. | Defect | Judgment Criterion | Partition | | | | | | | | | | |
|--------------------|-------------------------------|--|-------------|-------------------------------|--------------|-----------|--------------------|---|--------------------|---|-----------|---|-------|
| 1 | Spots | In accordance with <i>Screen Cosmetic Criteria (Operating) No.1.</i> | Minor | | | | | | | | | | |
| 2 | Lines | In accordance with <i>Screen Cosmetic Criteria (Operating) No.2.</i> | Minor | | | | | | | | | | |
| 3 | Bubbles in polarizer | <table border="1"> <thead> <tr> <th>Size : d mm</th> <th>Acceptable Qty in active area</th> </tr> </thead> <tbody> <tr> <td>$d \leq 0.3$</td> <td>Disregard</td> </tr> <tr> <td>$0.3 < d \leq 1.0$</td> <td>3</td> </tr> <tr> <td>$1.0 < d \leq 1.5$</td> <td>1</td> </tr> <tr> <td>$1.5 < d$</td> <td>0</td> </tr> </tbody> </table> | Size : d mm | Acceptable Qty in active area | $d \leq 0.3$ | Disregard | $0.3 < d \leq 1.0$ | 3 | $1.0 < d \leq 1.5$ | 1 | $1.5 < d$ | 0 | Minor |
| Size : d mm | Acceptable Qty in active area | | | | | | | | | | | | |
| $d \leq 0.3$ | Disregard | | | | | | | | | | | | |
| $0.3 < d \leq 1.0$ | 3 | | | | | | | | | | | | |
| $1.0 < d \leq 1.5$ | 1 | | | | | | | | | | | | |
| $1.5 < d$ | 0 | | | | | | | | | | | | |
| 4 | Scratch | In accordance with spots and lines operating cosmetic criteria. When the light reflects on the panel surface, the scratches are not to be remarkable. | Minor | | | | | | | | | | |
| 5 | Allowable density | Above defects should be separated more than 30mm each other. | Minor | | | | | | | | | | |
| 6 | Coloration | Not to be noticeable coloration in the viewing area of the LCD panels. Back-lit type should be judged with back-lit on state only. | Minor | | | | | | | | | | |
| 7 | Contamination | Not to be noticeable. | Minor | | | | | | | | | | |

13.3. Screen Cosmetic Criteria (Operating)

| No. | Defect | Judgment Criterion | Partition |
|-----|--------|--------------------|-----------|
| | | | |

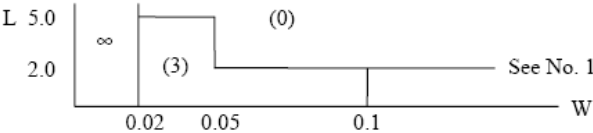
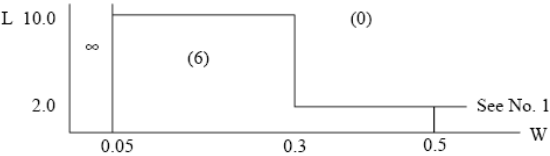

| 1 | Spots | <p>A) Clear Note :</p> <table border="1" data-bbox="491 324 1214 488"> <thead> <tr> <th>Size : d mm</th> <th>Acceptable Qty in active area</th> </tr> </thead> <tbody> <tr> <td>$d \leq 0.1$</td> <td>Disregard</td> </tr> <tr> <td>$0.1 < d \leq 0.2$</td> <td>3</td> </tr> <tr> <td>$0.2 < d \leq 0.3$</td> <td>2</td> </tr> <tr> <td>$0.3 < d$</td> <td>0</td> </tr> </tbody> </table> <p>Including pin holes and defective dots which must be within one pixel size.</p> <p>B) Unclear Size :</p> <table border="1" data-bbox="491 654 1206 817"> <thead> <tr> <th>Size : d mm</th> <th>Acceptable Qty in active area</th> </tr> </thead> <tbody> <tr> <td>$d \leq 0.2$</td> <td>Disregard</td> </tr> <tr> <td>$0.2 < d \leq 0.5$</td> <td>6</td> </tr> <tr> <td>$0.5 < d \leq 0.7$</td> <td>2</td> </tr> <tr> <td>$0.7 < d$</td> <td>0</td> </tr> </tbody> </table> | Size : d mm | Acceptable Qty in active area | $d \leq 0.1$ | Disregard | $0.1 < d \leq 0.2$ | 3 | $0.2 < d \leq 0.3$ | 2 | $0.3 < d$ | 0 | Size : d mm | Acceptable Qty in active area | $d \leq 0.2$ | Disregard | $0.2 < d \leq 0.5$ | 6 | $0.5 < d \leq 0.7$ | 2 | $0.7 < d$ | 0 | Minor |
|--------------------|-------------------------------|--|-------------|-------------------------------|--------------|-----------|--------------------|---|--------------------|---|-----------|---|-------------|-------------------------------|--------------|-----------|--------------------|---|--------------------|---|-----------|---|-------|
| Size : d mm | Acceptable Qty in active area | | | | | | | | | | | | | | | | | | | | | | |
| $d \leq 0.1$ | Disregard | | | | | | | | | | | | | | | | | | | | | | |
| $0.1 < d \leq 0.2$ | 3 | | | | | | | | | | | | | | | | | | | | | | |
| $0.2 < d \leq 0.3$ | 2 | | | | | | | | | | | | | | | | | | | | | | |
| $0.3 < d$ | 0 | | | | | | | | | | | | | | | | | | | | | | |
| Size : d mm | Acceptable Qty in active area | | | | | | | | | | | | | | | | | | | | | | |
| $d \leq 0.2$ | Disregard | | | | | | | | | | | | | | | | | | | | | | |
| $0.2 < d \leq 0.5$ | 6 | | | | | | | | | | | | | | | | | | | | | | |
| $0.5 < d \leq 0.7$ | 2 | | | | | | | | | | | | | | | | | | | | | | |
| $0.7 < d$ | 0 | | | | | | | | | | | | | | | | | | | | | | |
| 2 | Lines | <p>A) Clear</p>  <p>Note : () - Acceptable Qty in active area L - Length (mm) W - Width (mm) ∞ - Disregard</p> <p>B) Unclear</p>  | Minor | | | | | | | | | | | | | | | | | | | | |

'Clear' = The shade and size are not changed by VO.

'Unclear' = The shade and size are changed by VO.

13.4. Screen Cosmetic Criteria (Operating) (Continued)

| No. | Defect | Judgment Criterion | Partition |
|-----|-------------------|--|-----------|
| 3 | Rubbing line | Not to be noticeable. | |
| 4 | Allowable density | Above defects should be separated more than 10mm each other. | Minor |
| 5 | Rainbow | Not to be noticeable. | Minor |
| 6 | Dot size | To be 95% ~ 105% of the dot size (Typ.) in drawing. Partial defects of each dot (ex. pin-hole) should be treated as 'Spot'. (see | Minor |

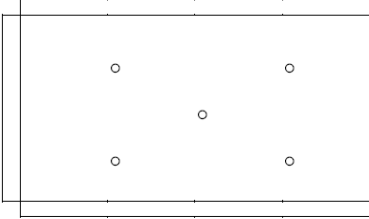
| | | <i>Screen Cosmetic Criteria (Operating) No.1)</i> | |
|---|---|--|-------|
| 7 | Uneven brightness (only back-lit type module) | Uneven brightness must be $B_{MAX} / B_{MIN} \leq 2$ - B_{MAX} : Max. value by measure in 5 points - B_{MIN} : Min. value by measure in 5 points Divide active area into 4 vertically and horizontally. Measure 5 points shown in the following figure. <div style="text-align: center;">  <p>○ : Measuring points</p> </div> | Minor |

Note :

- (1) Size : $d = (\text{long length} + \text{short length}) / 2$
- (2) The limit samples for each item have priority.
- (3) Complexed defects are defined item by item, but if the number of defects are defined in above table, the total number should not exceed 10.
- (4) In case of 'concentration', even the spots or the lines of 'disregarded' size should be not allowed.

Following three situations should be treated as 'concentration'.

- 7 or over defects in circle of '5mm.
- 10 or over defects in circle of '10mm.
- 20 or over defects in circle of '20mm.

14. PRECAUTIONS FOR USING LCD MODULES

Handing Precautions

- (1) The display panel is made of glass. Do not subject it to a mechanical shock by dropping it or impact.
- (2) If the display panel is damaged and the liquid crystal substance leaks out, be sure not to get any in your mouth. If the substance contacts your skin or clothes, wash it off using soap and water.
- (3) Do not apply excessive force to the display surface or the adjoining areas since this may cause the color tone to vary.
- (4) The polarizer covering the display surface of the LCD module is soft and easily scratched. Handle this polarizer carefully.
- (5) If the display surface becomes contaminated, breathe on the surface and gently wipe it with a soft dry cloth. If it is heavily contaminated, moisten cloth with one of the following solvents :
 - Isopropyl alcohol
 - Ethyl alcohol
- (6) Solvents other than those above-mentioned may damage the polarizer. Especially, do not use the following.
 - Water



- Ketone
- Aromatic solvents

(7) Exercise care to minimize corrosion of the electrode. Corrosion of the electrodes is accelerated by water droplets, moisture condensation or a current flow in a high-humidity environment.

(8) Install the LCD Module by using the mounting holes. When mounting the LCD module make sure it is free of twisting, warping and distortion. In particular, do not forcibly pull or bend the IO cable or the backlight cable.

(9) Do not attempt to disassemble or process the LCD module.

(10) NC terminal should be open. Do not connect anything.

(11) If the logic circuit power is off, do not apply the input signals.

(12) To prevent destruction of the elements by static electricity, be careful to maintain an optimum work environment.

- Be sure to ground the body when handling the LCD modules.
- Tools required for assembling, such as soldering irons, must be properly grounded.
- To reduce the amount of static electricity generated, do not conduct assembling and other work under dry conditions.
- The LCD module is coated with a film to protect the display surface. Exercise care when peeling off this protective film since static electricity may be generated.

Storage Precautions

When storing the LCD modules, avoid exposure to direct sunlight or to the light of fluorescent lamps. Keep the modules in bags (avoid high temperature, high humidity and low temperatures below 0°C). Whenever possible, the LCD modules should be stored in the same conditions in which they were shipped from our company.

Others

Liquid crystals solidify under low temperature (below the storage temperature range) leading to defective orientation or the generation of air bubbles (black or white). Air bubbles may also be generated if the module is subject to a low temperature.

If the LCD modules have been operating for a long time showing the same display patterns, the display patterns may remain on the screen as ghost images and a slight contrast irregularity may also appear. A normal operating status can be regained by suspending use for some time. It should be noted that this phenomenon does not adversely affect performance reliability.

To minimize the performance degradation of the LCD modules resulting from destruction caused by static electricity etc., exercise care to avoid holding the following sections when handling the modules.

- Exposed area of the printed circuit board.
- Terminal electrode sections.

15. USING LCD MODULES

Liquid Crystal Display Modules

LCD is composed of glass and polarizer. Pay attention to the following items when handling.

- (1) Please keep the temperature within specified range for use and storage. Polarization degradation, bubble generation or polarizer peel-off may occur with high temperature and high humidity.
- (2) Do not touch, push or rub the exposed polarizers with anything harder than an HB pencil lead (glass, tweezers, etc.).
- (3) N-hexane is recommended for cleaning the adhesives used to attach front/rear polarizers and reflectors made of organic substances which will be damaged by chemicals such as acetone, toluene, ethanol and isopropylalcohol.
- (4) When the display surface becomes dusty, wipe gently with absorbent cotton or other soft material like chamois soaked in petroleum benzine. Do not scrub hard to avoid damaging the display surface.
- (5) Wipe off saliva or water drops immediately, contact with water over a long period of time may cause deformation or color fading.
- (6) Avoid contacting oil and fats.
- (7) Condensation on the surface and contact with terminals due to cold will damage, stain or dirty the polarizers. After products are tested at low temperature they must be warmed up in a container before coming in contact with room temperature air.
- (8) Do not put or attach anything on the display area to avoid leaving marks on.
- (9) Do not touch the display with bare hands. This will stain the display area and degrade insulation between terminals (some cosmetics are determined to the polarizers).
- (10) As glass is fragile. It tends to become or chipped during handling especially on the edges. Please avoid dropping or jarring.

Installing LCD Modules

The hole in the printed circuit board is used to fix LCM as shown in the picture below. Attend to the following items when installing the LCM.

- (1) Cover the surface with a transparent protective plate to protect the polarizer and LC cell.

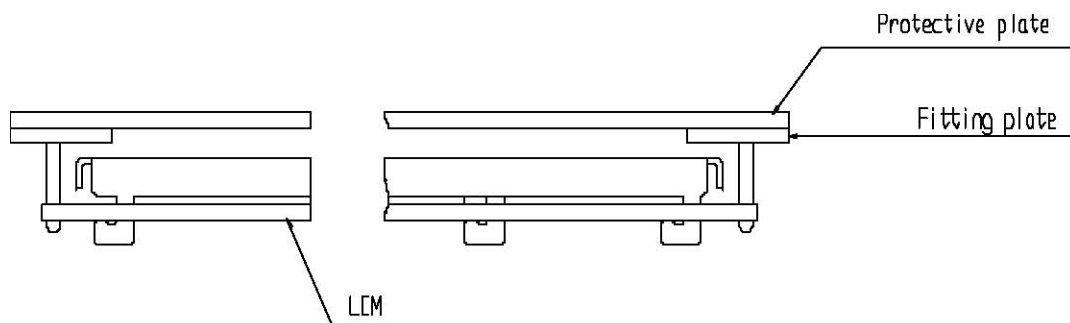

- (2) When assembling the LCM into other equipment, the spacer to the bit between the LCM and the fitting plate should have enough height to avoid causing stress to the module surface, refer to the individual specifications for measurements. The measurement tolerance should be 0.1mm.



Precaution for Handling LCD Modules

Since LCM has been assembled and adjusted with a high degree of precision, avoid applying excessive shocks to the module or making any alterations or modifications to it.

- (1) Do not alter, modify or change the the shape of the tab on the metal frame.
- (2) Do not make extra holes on the printed circuit board, modify its shape or change the positions of components to be attached.
- (3) Do not damage or modify the pattern writing on the printed circuit board.
- (4) Absolutely do not modify the zebra rubber strip (conductive rubber) or heat seal connector.
- (5) Except for soldering the interface, do not make any alterations or modifications with a soldering iron.
- (6) Do not drop, bend or twist LCM.

Electro-Static Discharge Control

Since this module uses a CMOS LSI, the same careful attention should be paid to electrostatic discharge as for an ordinary CMOS IC.

- (1) Make certain that you are grounded when handling LCM.
- (2) Before remove LCM from its packing case or incorporating it into a set, be sure the module and your body have the same electric potential.
- (3) When soldering the terminal of LCM, make certain the AC power source for the soldering iron does not leak.
- (4) When using an electric screwdriver to attach LCM, the screwdriver should be of ground potentiality to minimize as much as possible any transmission of electromagnetic waves produced sparks coming from the commutator of the motor.
- (5) As far as possible make the electric potential of your work clothes and that of the work bench the ground potential.
- (6) To reduce the generation of static electricity be careful that the air in the work is not too dried. A relative humidity of 50%60% is recommended.

Precaution for soldering to the LCM

- (1) Observe the following when soldering lead wire, connector cable and etc. to the LCM.
 - Soldering iron temperature : 280□C 10□C.
 - Soldering time : 3-4 sec.
 - Solder : eutectic solder.

If soldering flux is used, be sure to remove any remaining flux after finishing to soldering operation. (This does not apply in the case of a non-halogen type of flux.) It is recommended that you protect the LCD surface with a cover during soldering to prevent any damage dur to flux spatters.

(2) When soldering the electroluminescent panel and PC board, the panel and board should not be detached more than three times. This maximum number is determined by the temperature and time conditions mentioned above, though there may be some variance depending on the temperature of the soldering iron.

(3) When remove the electoluminescent panel from the PC board, be sure the solder has completely melted, the soldered pad on the PC board could be damaged.

Precautions for Operation

(1) Viewing angle varies with the change of liquid crystal driving voltage (VO). Adjust VO to show the best contrast.

(2) Driving the LCD in the voltage above the limit shortens its life.

(3) Response time is greatly delayed at temperature below the operating temperature range. However, this does not mean the LCD will be out of the order. It will recover when it returns to the specified temperature range.

(4) If the display area is pushed hard during operation, the display will become abnormal. However, it will return to normal if it is turned off and then back on.

(5) Condensation on terminals can cause an electrochemical reaction disrupting the terminal circuit. Therefore, it must be used under the relative condition of 40°C , 50% RH.

(6) When turning the power on, input each signal after the positive/negative voltage becomes stable.

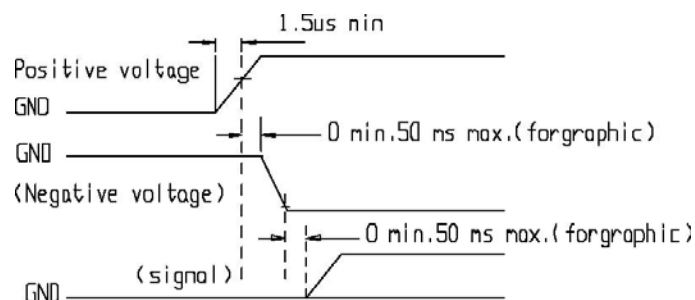

Storage

When storing LCDs as spares for some years, the following precaution are necessary.

(1) Store them in a sealed polyethylene bag. If properly sealed, there is no need for dessicant.

(2) Store them in a dark place. Do not expose to sunlight or fluorescent light, keep the temperature between 0°C and 35°C.

(3) The polarizer surface should not come in contact with any other objects. (We advise you to store them in the container in which they were shipped.)

Safety

(1) It is recommended to crush damaged or unnecessary LCDs into pieces and wash them off with solvents such as acetone and ethanol, which should later be burned.

(2) If any liquid leaks out of a damaged glass cell and comes in contact with the hands, wash off thoroughly with soap and water.

Limited Warranty

Unless agreed between YAOYU and customer, YAOYU will replace or repair any of its LCD modules which are found to be functionally defective when inspected in accordance with YAOYU LCD acceptance standards (copies available upon request) for a period of one year from date of shipments. Cosmetic/visual defects must be returned to YAOYU within 90 days of shipment. Confirmation of such date shall be based on freight documents. The warranty liability of YAOYU limited to repair and/or replacement on the terms set forth above. YAOYU will not be responsible for any subsequent or consequential events.

Return LCM under warranty

No warranty can be granted if the precautions stated above have been disregarded. The typical examples of violations are :

- Broken LCD glass.



- PCB eyelet's damaged or modified.
- PCB conductors damaged.
- Circuit modified in any way, including addition of components.
- PCB tampered with by grinding, engraving or painting varnish.
- soldering to or modifying the bezel in any manner.

Module repairs will be invoiced to the customer upon mutual agreement. Modules must be returned with sufficient description of the failures or defects. Any connectors or cable installed by the customer must be removed completely without damaging the PCB eyelet's, conductors and terminals.