

SPECIFICATION



YMFP-G240160B-1DPSGSD

September 28, 2007
Version 1.01



RECORDS OF REVISION

DATE	REVISED NO.	REVISED DESCRIPTIONS	PREPARED	CHECKED	APPROVED
Mar-23-2006	1.00	FIRST ISSUE	tfb		
September 28, 2007	1.01	Amend wrappage and address	ynn		

CONTENTS

1.	FEATURES-.....	1
2.	BLOCK DIAGRAM &APPLICATION CIRCUIT	1
3.	OUTLINE DIMENSIONS-.....	3
4.	ABSOLUTE MAXIMUM RATING	4
5.	ELECTRICAL CHARACTERISTICS	4
6.	OPTICAL CHARACTERISTICS-.....	5
7.	TIMING CHARACTERISTICS	6
8.	DISPLAY CONTROL INSTRUCTION	10
9.	DISPLAY CONTROL FUNCTIONS-.....	30
10.	CHARACTER GENERATOR-.....	44
11.	INTERFACE PIN CONNECTIONS-.....	50
12.	RELIABILITY	52
13.	QUALITY GUARANTEE	53
14.	INSPECTION CRITERIA	54
15.	PRECAUTIONS FOR USING LCD MODULES	55
16.	USING LCD MODULES	56

1. FEATURES :

ITEM	STANDARD VALUE	UNIT
Display Type	240 *160 dots	-
LCD Type	■FSTN Transflective, Position, Extend TEMP	-
LCD Duty	1/160	-
LCD Bias	1/13	-
Viewing Direction	6:00	-
Backlight Type	■LED(Green)	-
Interface	6800 Series or 8080 series	-
Driver IC	■ SED13305F0A	-
Module Dimension	92.0(W) X 78.4(H) X11.3(MAX)(T)	mm
Effective Display Area	71.97(W) X47.97(H)	mm
Dot Size	0.27(W) X 0.27(H)	mm
Dot Pitch	0.30W) X 0.30 (H)	mm

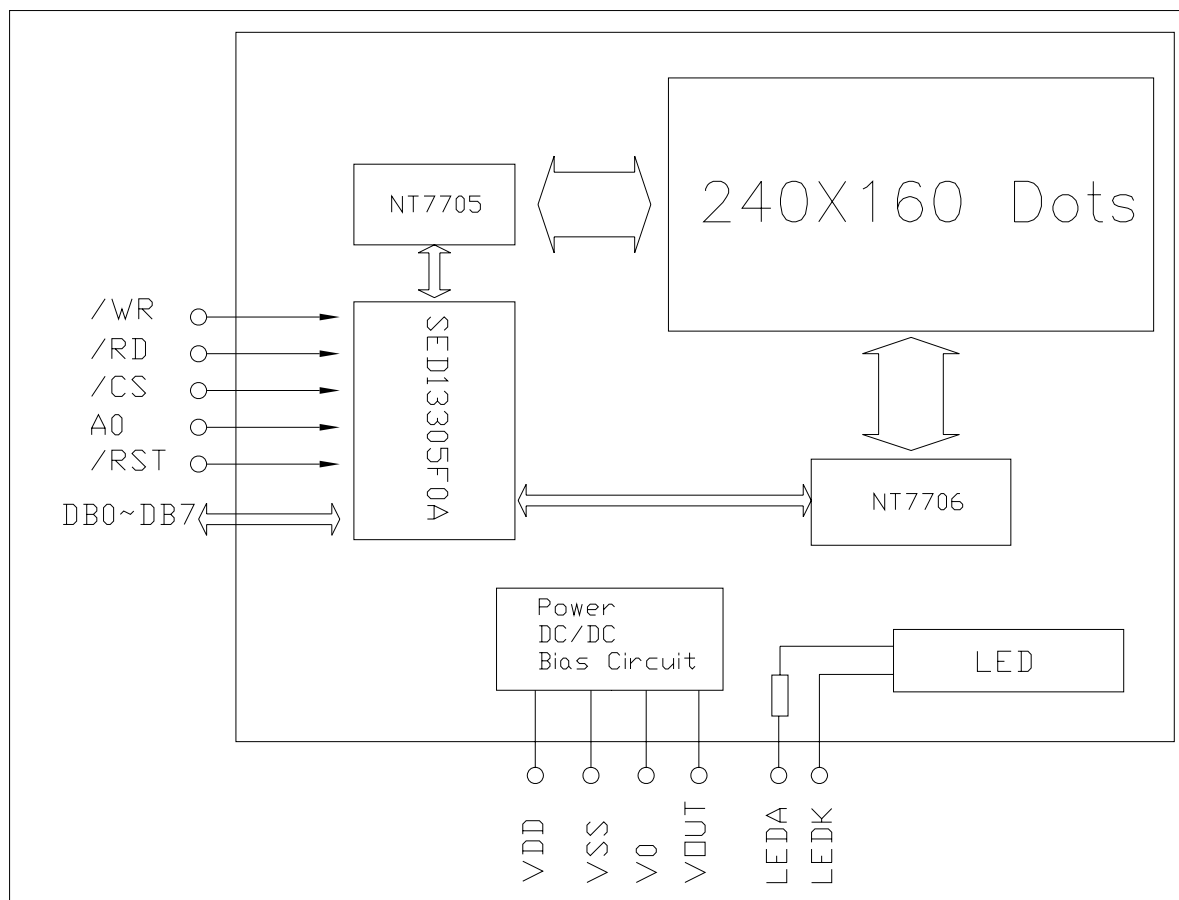
2. BLOCK DIAGRAM &APPLICATION CIRCUIT :

Built-in SED13305F0A Application

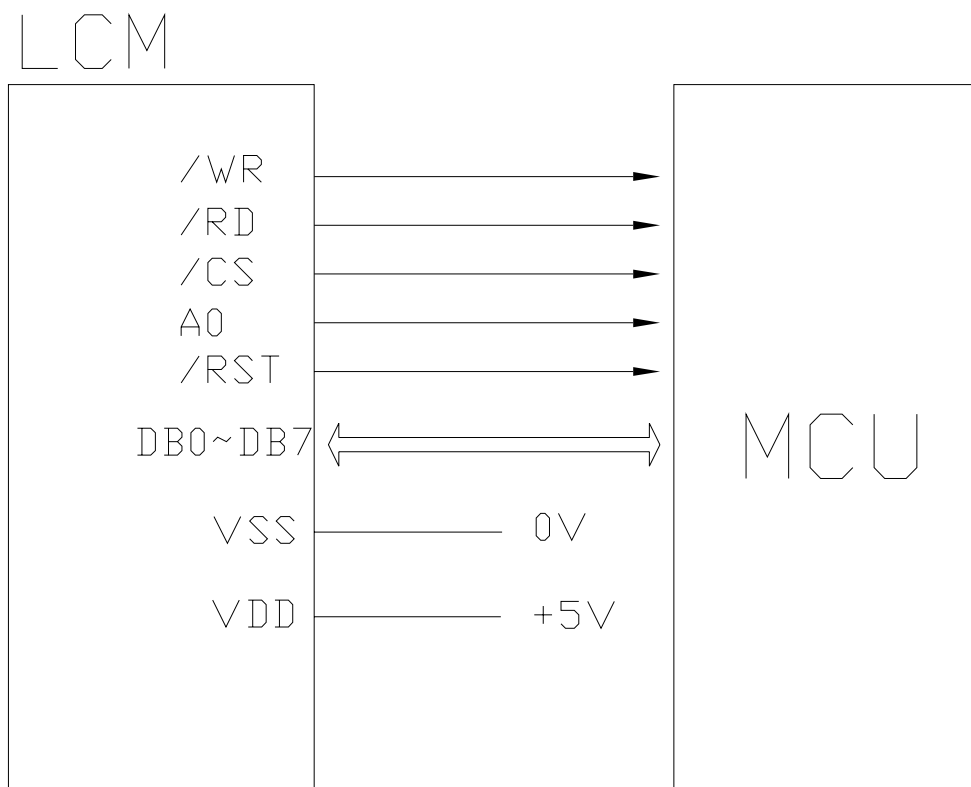

Note:

VR1(Rheostat) , Contrast regulator.

3. OUTLINE DIMENSIONS

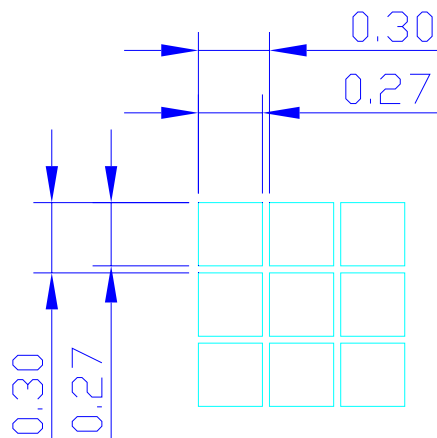
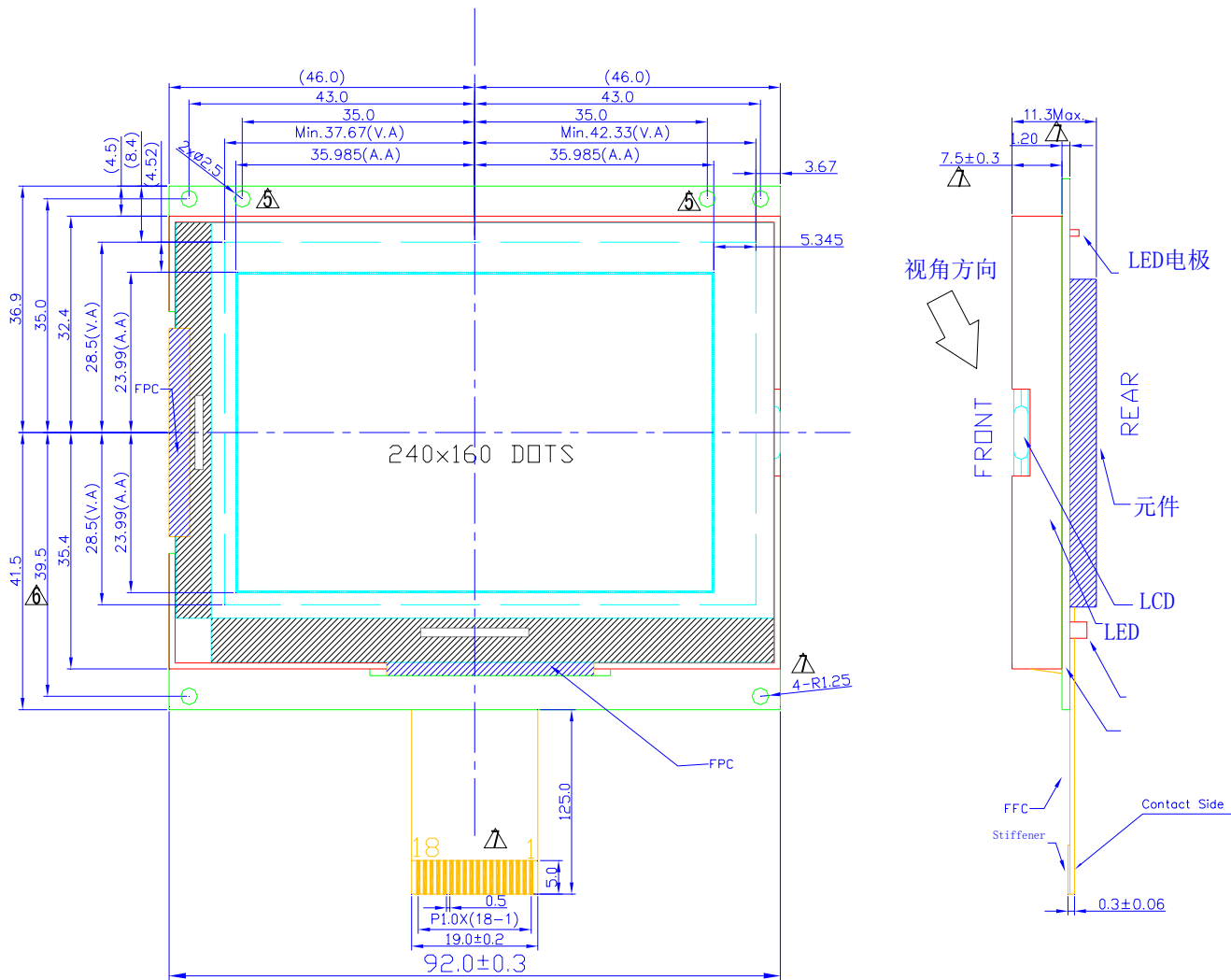

4. ABSOLUTE MAXIMUM RATING

ITEM	SYMBOL	CONDITION	STANDARD VALUE			UNIT
			MIN	TYP	MAX	
POWER SUPPLY FOR LOGIC	VDD	Ta=25°C	-0.3	—	7.0	V
INPUT VOLTAGE	VIN	Ta=25°C	-0.3	—	VDD+0.3	V
Module OPERATION TEMPERATURE	TOPR	---	-20	—	+70	°C
Module STORAGE TEMPERATURE	TSTG	---	-30	—	+80	°C
Storage Humidity	H _D	Ta < 40 °C	-		90	%RH

5. ELECTRICAL CHARACTERISTICS

ITEM	SYMBOL	CONDITION	MIN	TYP	MAX	UNIT
Supply Voltage (logic)	VDD-VSS	-	4.5	5	5.5	V
Supply Voltage (LCD)	VDD-V0	Ta= +25°C	-	+15	-	V
Input signal voltage	V-IH	“H” level	0.5VDD	-	VDD	V
	V-IL	“L” level	VSS	-	0.2 VDD	V
Output signal voltage	V-OH	“H” level	2.4	-	-	V
	VOL	“H” level	-	-	VSS+0.4	V
Supply Current (logic)	IDD	VDD=5.0V	-	90	-	mA
Backlight Voltage	V-BL	LED	-	3.1	-	V
Backlight Current	I-BL	LED	-	70	100	mA
Backlight Driver Wave	-	-	-	-	-	-
Backlight Brightness	-	-	-	-	-	-
Backlight Life Time	-	-	-	-	-	-

6. OPTICAL CHARACTERISTICS

Item	Symbol	Condition	Min	Typ	Max	Unit	Remarks	Note
Response Time	Tr	-	-	233	-	ms	-	1
	Tf	-	-	133	-	ms	-	1
Contrast Ratio	Cr	-	-	8.3	-	-	-	2
Viewing Angle Range	θ	Cr ≥ 2	28	-	-	deg	∅= 90	3
			32	-	-	deg	∅ = 270	3
			44	-	-	deg	∅ = 0	3
			33	-	-	deg	∅ = 180	3

Note 1. Definition of response time

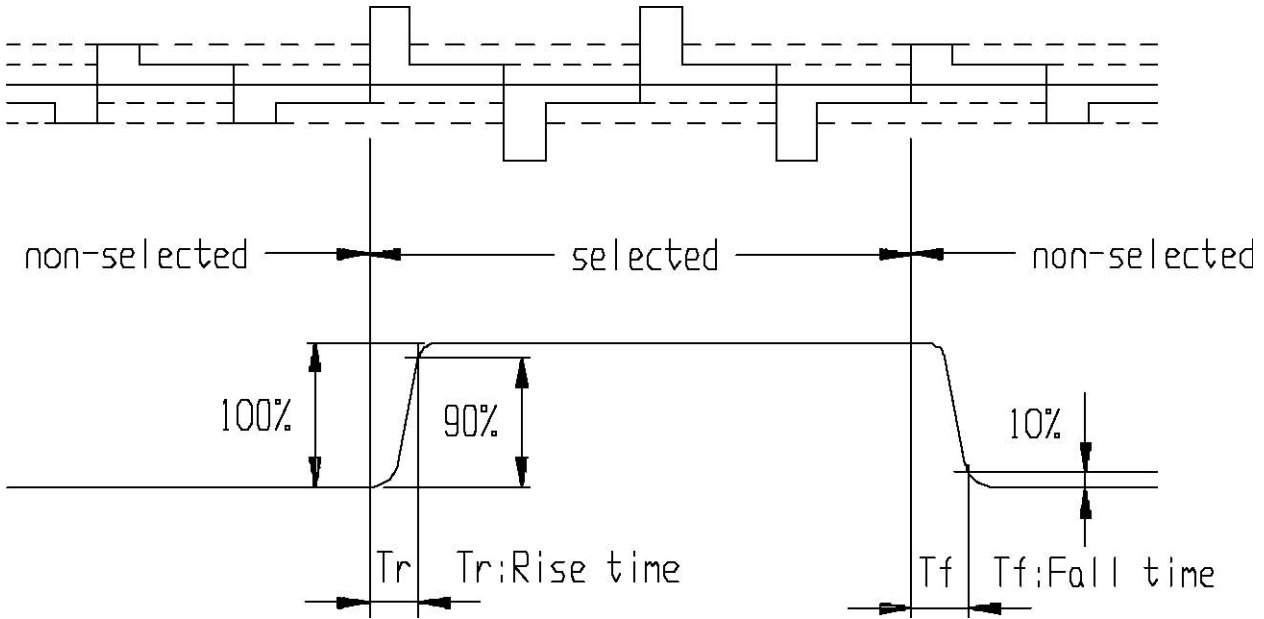

Note 2. Definition of Contrast Ratio 'Cr'

$$Cr = \frac{\text{Brightness of non-selected segment}(B2)}{\text{Brightness of selected segment}(B1)}$$

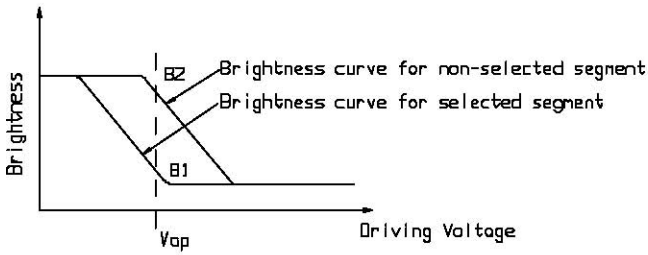

Note 3. Definition of Viewing Angle Range 'q'

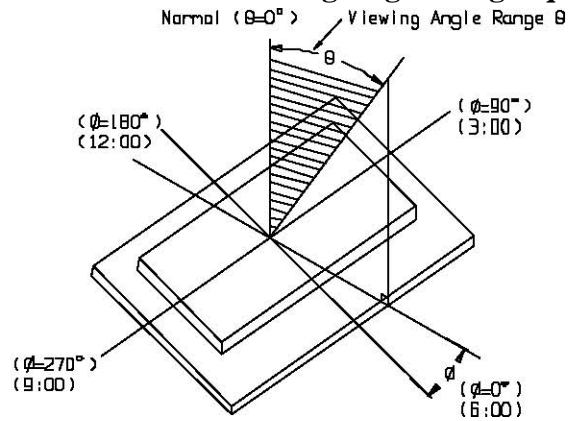

7. TIMING CHARACTERISTICS

R1 connected with 0Ω resistor, 6800 series

R2 connected with 0Ω resistor, 8080 series

7.1 SED1335 Timing

7.1.1. 8080 Series Timing

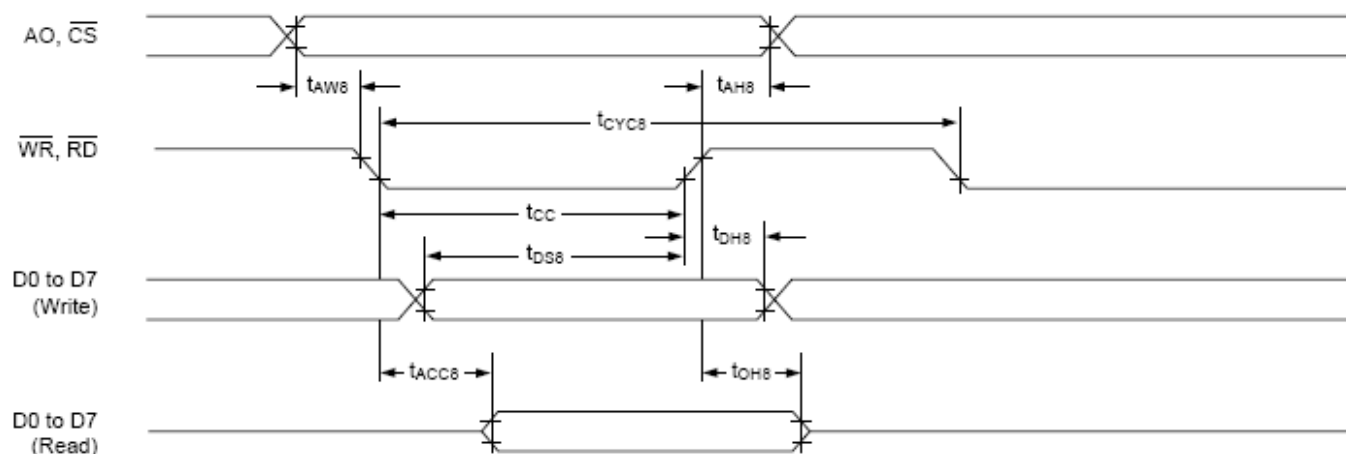

$T_a = -20$ to 75°C

Signal	Symbol	Parameter	VDD = 4.5 to 5.5V		VDD = 2.7 to 4.5V		Unit	Condition
			min	max	min	max		
A0, $\overline{\text{CS}}$	tAH8	Address hold time	10	—	10	—	ns	CL = 100pF
	tAW8	Address setup time	0	—	0	—	ns	
$\overline{\text{WR}}, \overline{\text{RD}}$	tCYC8	System cycle time	See note.	—	See note.	—	ns	
	tCC	Strobe pulsewidth	120	—	150	—	ns	
D0 to D7	tDS8	Data setup time	120	—	120	—	ns	
	tDH8	Data hold time	5	—	5	—	ns	
	tACC8	$\overline{\text{RD}}$ access time	—	50	—	80	ns	
	tOH8	Output disable time	10	50	10	55	ns	

Note: For memory control and system control commands:

$$t_{CYC8} = 2t_c + t_{CC} + t_{CEA} + 75 > t_{ACV} + 245$$

For all other commands:

$$t_{CYC8} = 4t_c + t_{CC} + 30$$

7.1.2. 6800 Series Timing

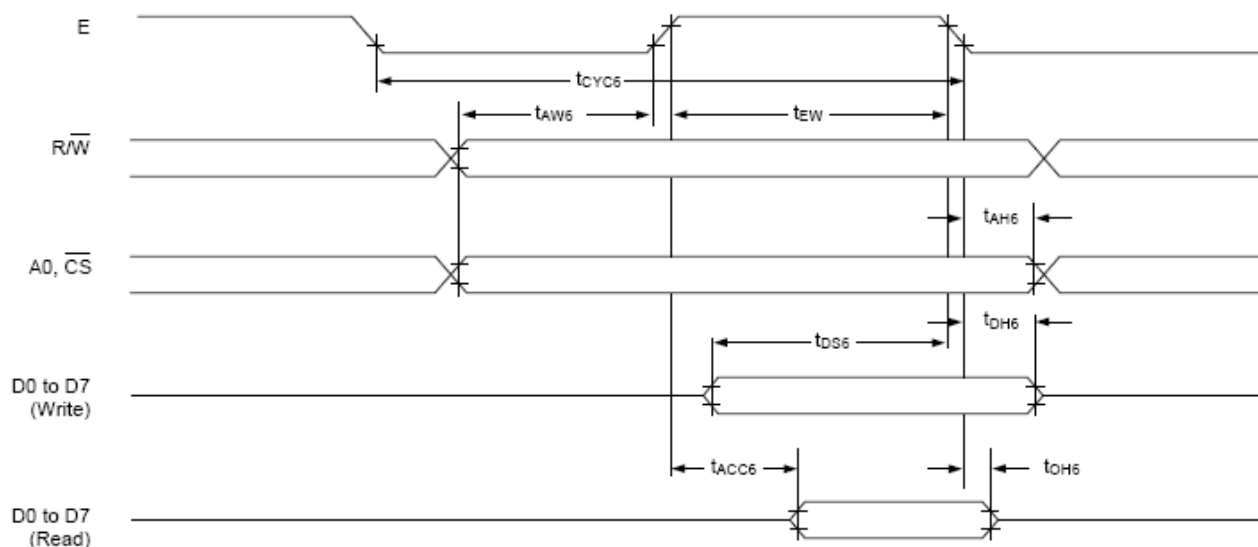

Note: t_{CYC6} indicates the interval during which CS is LOW and E is HIGH.

$T_a = -20$ to 75°C

Signal	Symbol	Parameter	VDD = 4.5 to 5.5V		VDD = 2.7 to 4.5V		Unit	Condition
			min	max	min	max		
A0, CS, R/W	t_{CYC6}	System cycle time	See note.	—	See note.	—	ns	CL = 100 pF
	t_{AW6}	Address setup time	0	—	10	—	ns	
	t_{AH6}	Address hold time	0	—	0	—	ns	
D0 to D7	t_{DS6}	Data setup time	100	—	120	—	ns	
	t_{DH6}	Data hold time	0	—	0	—	ns	
	t_{OH6}	Output disable time	10	50	10	75	ns	
	t_{ACC6}	Access time	—	85	—	130	ns	
E	t_{EW}	Enable pulsewidth	120	—	150	—	ns	

Note: For memory control and system control commands:

$$t_{CYC6} = 2t_C + t_{EW} + t_{CEA} + 75 > t_{ACV} + 245$$

For all other commands:

$$t_{CYC6} = 4t_C + t_{EW} + 30$$

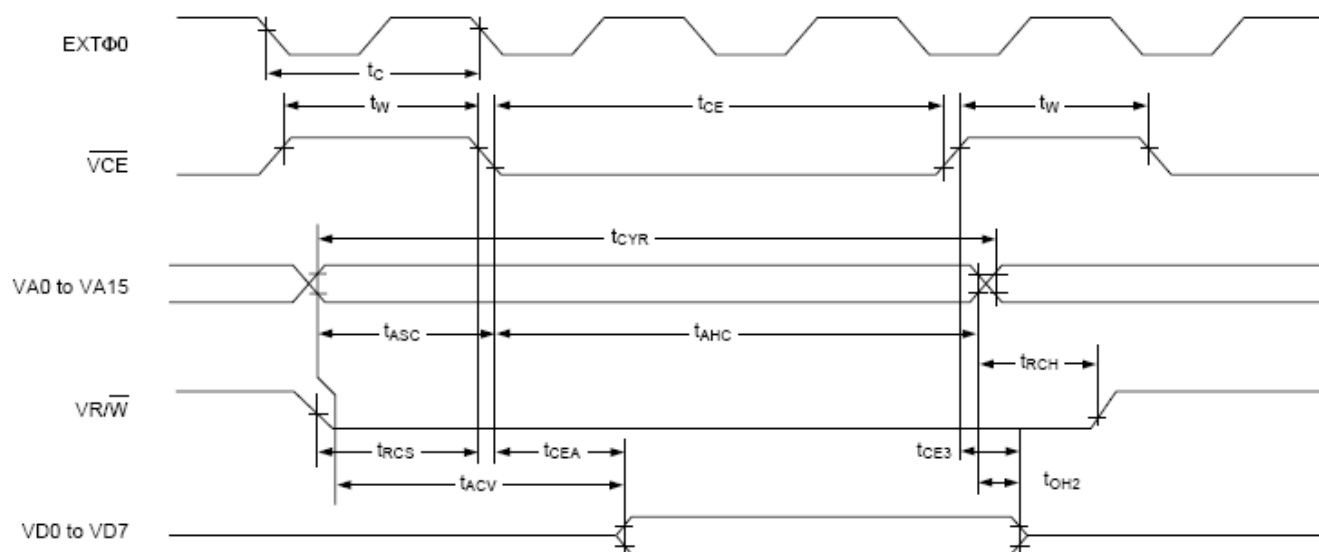
7.1.3. Display memory read timing

 $T_a = -20 \text{ to } 75^\circ\text{C}$

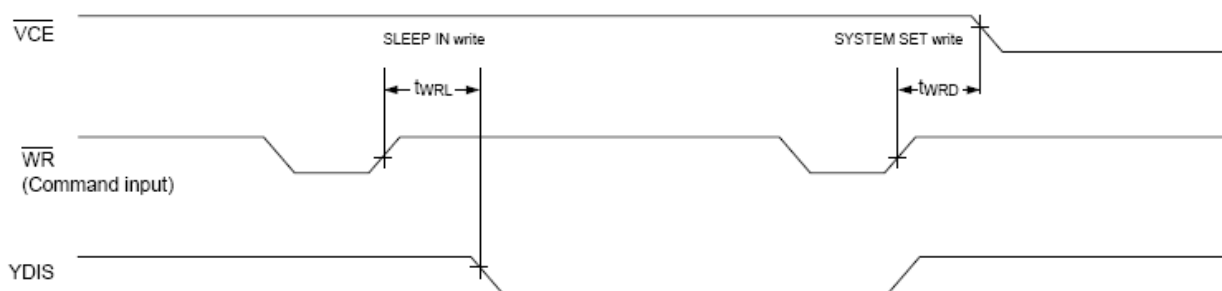
Signal	Symbol	Parameter	VDD = 4.5 to 5.5V		VDD = 2.7 to 4.5V		Unit	Condition
			min	max	min	max		
EXT $\phi 0$	t_c	Clock period	100	—	125	—	ns	CL = 100 pF
\overline{VCE}	t_w	\overline{VCE} HIGH-level pulsewidth	$t_c - 50$	—	$t_c - 50$	—	ns	
	t_{ce}	\overline{VCE} LOW-level pulsewidth	$2t_c - 30$	—	$2t_c - 30$	—	ns	
VA0 to VA15	t_{cyr}	Read cycle time	$3t_c$	—	$3t_c$	—	ns	
	t_{asc}	Address setup time to falling edge of \overline{VCE}	$t_c - 70$	—	$t_c - 100$	—	ns	
	t_{ahc}	Address hold time from falling edge of \overline{VCE}	$2t_c - 30$	—	$2t_c - 40$	—	ns	
\overline{VRD}	t_{rCS}	Read cycle setup time to falling edge of \overline{VCE}	$t_c - 45$	—	$t_c - 60$	—	ns	
	t_{rCH}	Read cycle hold time from rising edge of \overline{VCE}	$0.5t_c$	—	$0.5t_c$	—	ns	
VD0 to VD7	t_{acv}	Address access time	—	$3t_c - 100$	—	$3t_c - 115$	ns	
	t_{cea}	\overline{VCE} access time	—	$2t_c - 80$	—	$2t_c - 90$	ns	
	t_{oh2}	Output data hold time	0	—	0	—	ns	
	t_{ce3}	\overline{VCE} to data off time	0	—	0	—	ns	

7.1.4. SLEEP in command timing

 $T_a = -20 \text{ to } 75^\circ\text{C}$

Signal	Symbol	Parameter	VDD = 4.5 to 5.5V		VDD = 2.7 to 4.5V		Unit	Condition
			min	max	min	max		
$\overline{\text{WR}}$	tWRD	$\overline{\text{VCE}}$ falling-edge delay time	See note 1.	—	See note 1.	—	ns	CL = 100 pF
	tWRL	YDIS falling-edge delay time	—	See note 2.	—	See note 2.	ns	

Notes:

1. $t_{\text{WRD}} = 18t_c + t_{\text{OSS}} + 40$ (t_{OSS} is the time delay from the sleep state until stable operation)
2. $t_{\text{WRL}} = 36t_c \times [\text{TC/R}] \times [\text{L/F}] + 70$

8. Display Control Instruction
Please Consult SED1335 Data Sheet
8.1. The Command Set

Class	Command	Code											Hex	Command Description	Command Read Parameters	
		\overline{RD}	\overline{WR}	A0	D7	D6	D5	D4	D3	D2	D1	D0			No. of Bytes	Section
System control	SYSTEM SET	1	0	1	0	1	0	0	0	0	0	0	40	Initialize device and display	8	8.2.1
	SLEEP IN	1	0	1	0	1	0	1	0	0	1	1	53	Enter standby mode	0	8.2.2
Display control	DISP ON/OFF	1	0	1	0	1	0	1	1	0	0	D	58, 59	Enable and disable display and display flashing	1	8.3.1
	SCROLL	1	0	1	0	1	0	0	0	1	0	0	44	Set display start address and display regions	10	8.3.2
	CSRFORM	1	0	1	0	1	0	1	1	1	0	1	5D	Set cursor type	2	8.3.3
	CGRAM ADR	1	0	1	0	1	0	1	1	1	0	0	5C	Set start address of character generator RAM	2	8.3.6
	CSRDIR	1	0	1	0	1	0	0	1	1	CD 1	CD 0	4C to 4F	Set direction of cursor movement	0	8.3.4
	HDOT SCR	1	0	1	0	1	0	1	1	0	1	0	5A	Set horizontal scroll position	1	8.3.7
	OVLAY	1	0	1	0	1	0	1	1	0	1	1	5B	Set display overlay format	1	8.3.5
Drawing control	CSRW	1	0	1	0	1	0	0	0	1	1	0	46	Set cursor address	2	8.4.1
	CSRR	1	0	1	0	1	0	0	0	1	1	1	47	Read cursor address	2	8.4.2
Memory control	MWRITE	1	0	1	0	1	0	0	0	0	1	0	42	Write to display memory	—	8.5.1
	MREAD	1	0	1	0	1	0	0	0	0	1	1	43	Read from display memory	—	8.5.2

Notes:

1. In general, the internal registers of the SED1335 series are modified as each command parameter is input. However, the microprocessor does not have to set all the parameters of a command and may send a new command before all parameters have been input. The internal registers for the parameters that have been input will have been changed but the remaining parameter registers are unchanged.

2-byte parameters (where two bytes are treated as 1 data item) are handled as follows:

a. CSRW, CSRR: Each byte is processed individually. The microprocessor may read or write just the low byte of the cursor address.

b. SYSTEM SET, SCROLL, CGRAM ADR: Both parameter bytes are processed together. If the command is changed after half of the parameter has been input, the single byte is ignored.

2. APL and APH are 2-byte parameters, but are treated as two 1-byte parameters.

8.2. System Control Commands

8.2.1. SYSTEM SET

Initializes the device, sets the window sizes, and selects the LCD interface format. Since this command sets the basic operating parameters of the SED1335 series, an

incorrect SYSTEM SET command may cause other commands to operate incorrectly.

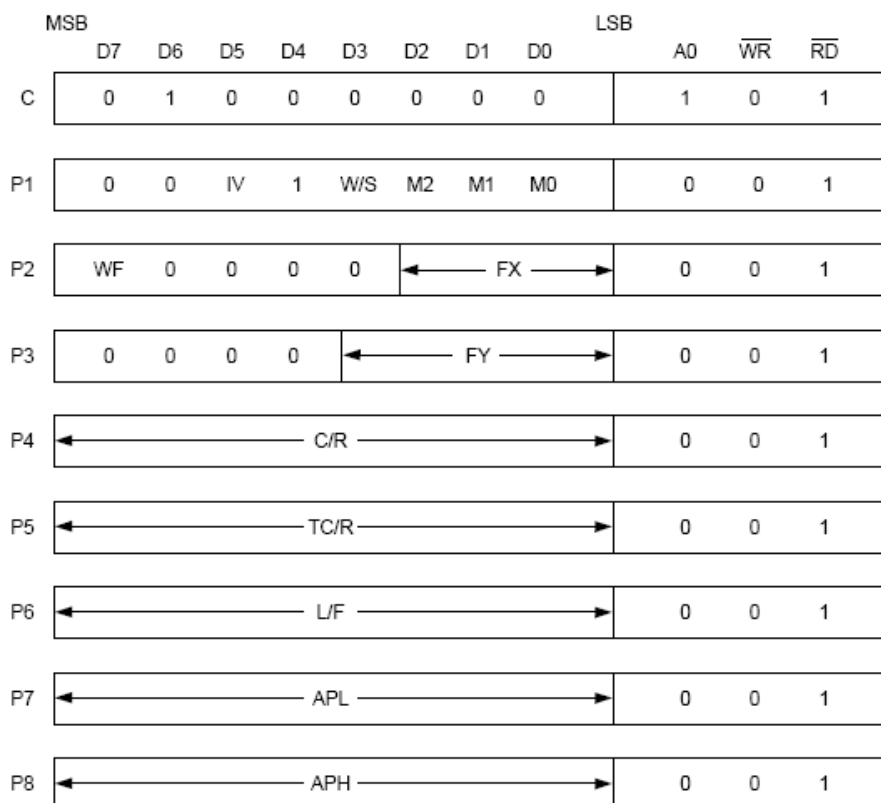

Figure 1. SYSTEM SET instruction

8.2.1.1. C

This control byte performs the following:

1. Resets the internal timing generator
2. Disables the display
3. Cancels sleep mode

Parameters following P1 are not needed if only canceling sleep mode.

8.2.1.2. M0

Selects the internal or external character generator ROM. The internal character generator ROM contains 160, 5 × 7 pixel characters, as shown in figure 70. These characters are fixed at fabrication by the metallization mask. The external character generator ROM, on the other hand, can contain up to 256 user-defined characters.

M0 = 0: Internal CG ROM

M0 = 1: External CG ROM

Note that if the CG ROM address space overlaps the display memory address space, that portion of the display memory cannot be written to.

8.2.1.3. M1

Selects the memory configuration for user-definable characters. The CG RAM codes select one of the 64 codes shown in figure 46.

M1 = 0: No D6 correction.

The CG RAM1 and CG RAM2 address spaces are not contiguous, the CG RAM1 address space is treated as character generator RAM, and the CG RAM2 address space is treated as character generator ROM.

M1 = 1: D6 correction.

The CG RAM1 and CG RAM2 address spaces are contiguous and are both treated as character generator RAM.

8.2.1.4. M2

Selects the height of the character bitmaps. Characters more than 16 pixels high can be displayed by creating a bitmap for each portion of each character and using the SED1335 series graphics mode to reposition them.

M2 = 0: 8-pixel character height (2716 or equivalent ROM)

M2 = 1: 16-pixel character height (2732 or equivalent ROM)

8.2.1.5. W/S

Selects the LCD drive method.

W/S = 0: Single-panel drive

W/S = 1: Dual-panel drive

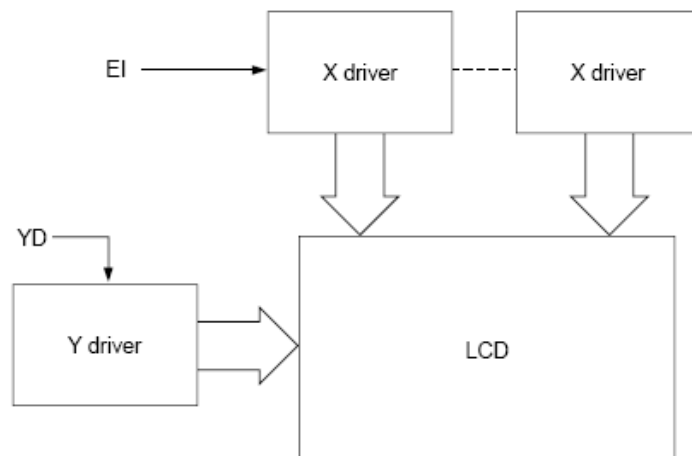

Figure 2. Single-panel display

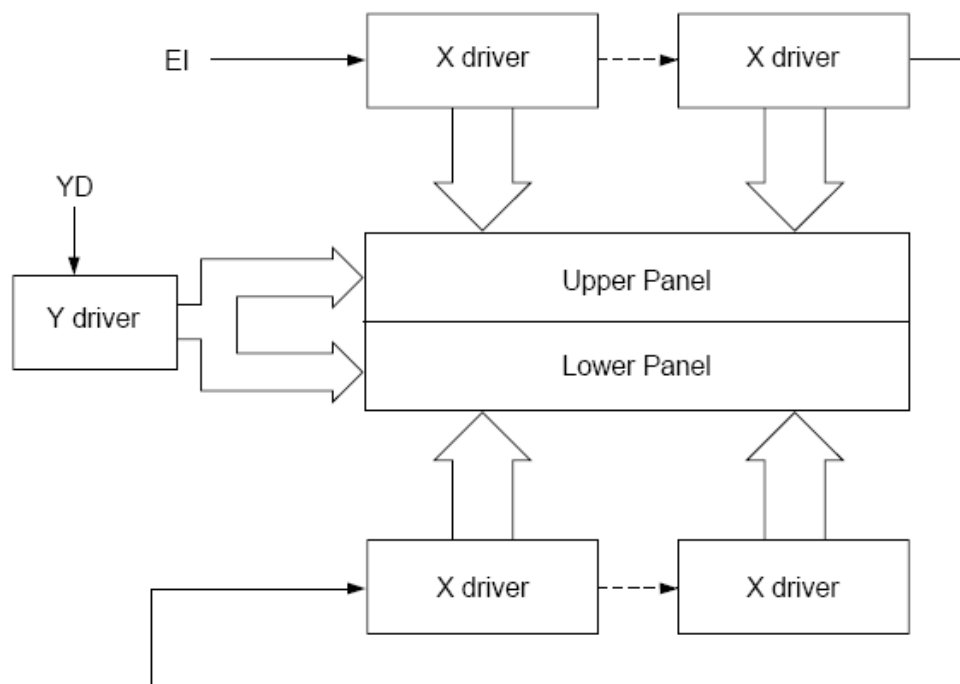

Figure 3. Above and below two-panel display

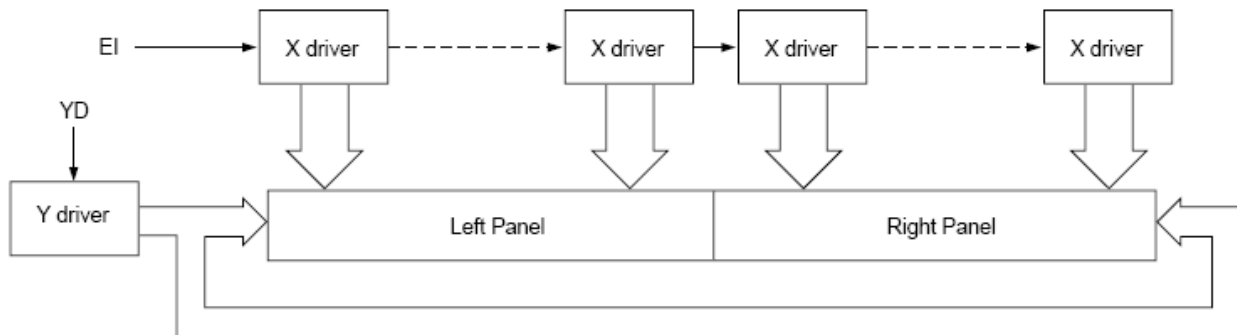

Figure 4. Left-and-right two-panel display

Note

There are no Seiko Epson LCD units in the configuration shown in Figure 4.

Table 2. LCD parameters

Parameter	W/S = 0		W/S = 1	
	IV = 1	IV = 0	IV = 1	IV = 0
C/R	C/R	C/R	C/R	C/R
TC/R	TC/R	TC/R (See note 1.)	TC/R	TC/R
L/F	L/F	L/F	L/F	L/F
SL1	00H to L/F	00H to L/F + 1 (See note 2.)	(L/F) / 2	(L/F) / 2
SL2	00H to L/F	00H to L/F + 1 (See note 2.)	(L/F) / 2	(L/F) / 2
SAD1	First screen block	First screen block	First screen block	First screen block
SAD2	Second screen block	Second screen block	Second screen block	Second screen block
SAD3	Third screen block	Third screen block	Third screen block	Third screen block
SAD4	Invalid	Invalid	Fourth screen block	Fourth screen block
Cursor move- ment range	Continuous movement over whole screen		Above-and-below configuration: continuous movement over whole screen	

Notes:

1. See table 26 for further details on setting the C/R and TC/R parameters when using the HDOT SCR command.
2. The value of SL when IV = 0 is equal to the value of SL when IV = 1, plus one.

8.2.1.6. IV

Screen origin compensation for inverse display. IV is usually set to 1.

The best way of displaying inverted characters is to Exclusive-OR the text layer with the graphics background layer. However, inverted characters at the top or

left of the screen are difficult to read as the character origin is at the top-left of its bitmap and there are no background pixels either above or to the left of these characters.

The IV flag causes the SED1335 series to offset the text screen against the graphics back layer by one vertical pixel. Use the horizontal pixel scroll function (HDOT SCR) to shift the text screen 1 to 7 pixels to the right. All characters will then have the necessary surrounding background pixels that ensure easy reading of the inverted characters.

See Section 10.5 for information on scrolling.

IV = 0: Screen top-line correction

IV = 1: No screen top-line correction

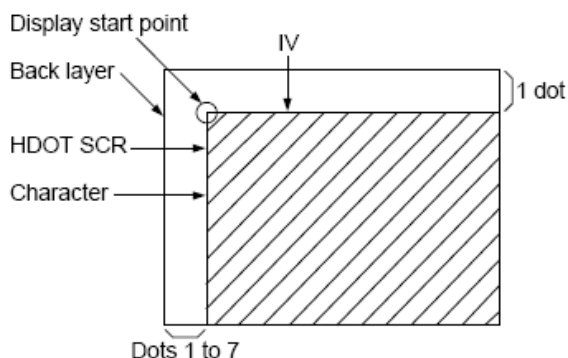

Figure 5. IV and HDOT SCR adjustment

8.2.1.7. FX

Define the horizontal character size. The character width in pixels is equal to $FX + 1$, where FX can range from 00 to 07H inclusive. If data bit 3 is set (FX is in the range 08 to 0FH) and an 8-pixel font is used, a space is inserted between characters.

Table 3. Horizontal character size selection

HEX	FX				[FX] character width (pixels)
	D3	D2	D1	D0	
00	0	0	0	0	1
01	0	0	0	1	2
↓	↓	↓	↓	↓	↓
07	0	1	1	1	8

Since the SED1335 series handles display data in 8-bit units, characters larger than 8 pixels wide must be formed from 8-pixel segments. As Figure 6 shows, the remainder of the second eight bits are not displayed. This also applies to the second screen layer.

In graphics mode, the normal character field is also eight pixels. If a wider character field is used, any remainder in the second eight bits is not displayed.

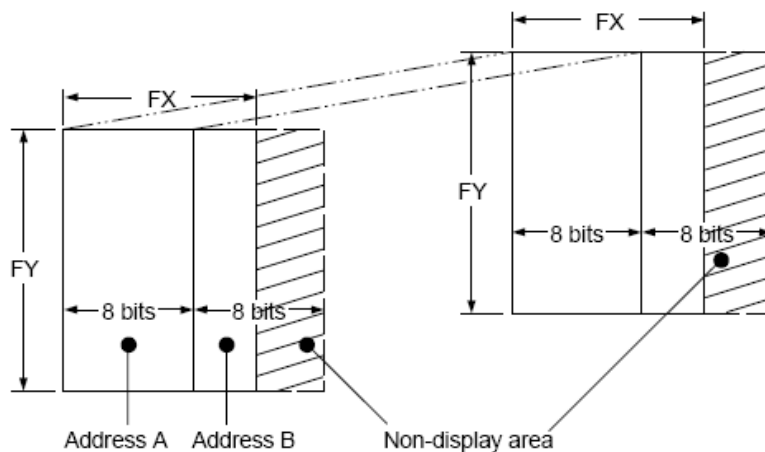

Figure 6. FX and FY display addresses

8.2.1.8. WF

Selects the AC frame drive waveform period. WF is usually set to 1.

WF = 0: 16-line AC drive

WF = 1: two-frame AC drive

In two-frame AC drive, the WF period is twice the frame period.

In 16-line AC drive, WF inverts every 16 lines.

Although 16-line AC drive gives a more readable display, horizontal lines may appear when using high LCD drive voltages or at high viewing angles.

8.2.1.9. FY

Sets the vertical character size. The height in pixels is equal to FY + 1.

FY can range from 00 to 0FH inclusive.

Set FY to zero (vertical size equals one) when in graphics mode.

Table 4. Vertical character size selection

FY					[FY] character height (pixels)
HEX	D3	D2	D1	D0	
00	0	0	0	0	1
01	0	0	0	1	2
↓	↓	↓	↓	↓	↓
07	0	1	1	1	8
↓	↓	↓	↓	↓	↓
0E	1	1	1	0	15
0F	1	1	1	1	16

Table 5. Display line address range

C/R									[C/R] bytes per display line
HEX	D7	D6	D5	D4	D3	D2	D1	D0	
00	0	0	0	0	0	0	0	0	1
01	0	0	0	0	0	0	0	1	2
↓	↓	↓	↓	↓	↓	↓	↓	↓	↓
4F	0	1	0	0	1	1	1	1	80
↓	↓	↓	↓	↓	↓	↓	↓	↓	↓
EE	1	1	1	0	1	1	1	0	239
EF	1	1	1	0	1	1	1	1	240

8.2.1.10. C/R

Sets the address range covered by one display line, that is, the number of characters less one, multiplied by the number of horizontal bytes per character.

C/R can range from 0 to 239.

For example, if the character width is 10 pixels, then the address range is equal to twice the number of characters, less 2. See Section 16.1.1 for the calculation of C/R.

[C/R] cannot be set to a value greater than the address range. It can, however, be set smaller than the address range, in which case the excess display area is blank. The number of excess pixels must not exceed 64.

8.2.1.11. TC/R

Sets the length, including horizontal blanking, of one line. The line length is equal to $TC/R + 1$, where TC/R can range from 0 to 255.

TC/R must be greater than or equal to $C/R + 4$. Provided this condition is satisfied, $[TC/R]$ can be set according to

the equation given in section 16.1.1 in order to hold the frame period constant and minimize jitter for any given main oscillator frequency, f_{osc} .

Table 6. Line length selection

TC/R									[TC/R] line length (bytes)
HEX	D7	D6	D5	D4	D3	D2	D1	D0	
00	0	0	0	0	0	0	0	0	1
01	0	0	0	0	0	0	0	1	2
↓	↓	↓	↓	↓	↓	↓	↓	↓	↓
52	0	1	0	1	0	0	1	0	83
↓	↓	↓	↓	↓	↓	↓	↓	↓	↓
FE	1	1	1	1	1	1	1	0	255
FF	1	1	1	1	1	1	1	1	256

8.2.1.12. L/F

Sets the height, in lines, of a frame. The height in lines is equal to $L/F + 1$, where L/F can range from 0 to 255.

Table 7. Frame height selection

L/F									[L/F] lines per frame
HEX	D7	D6	D5	D4	D3	D2	D1	D0	
00	0	0	0	0	0	0	0	0	1
01	0	0	0	0	0	0	0	1	2
↓	↓	↓	↓	↓	↓	↓	↓	↓	↓
7F	0	1	1	1	1	1	1	1	128
↓	↓	↓	↓	↓	↓	↓	↓	↓	↓
FE	1	1	1	1	1	1	1	0	255
FF	1	1	1	1	1	1	1	1	256

If W/S is set to 1, selecting two-screen display, the number of lines must be even and L/F must, therefore, be an odd number.

8.2.1.13. AP

Defines the horizontal address range of the virtual screen.
APL is the least significant byte of the address.

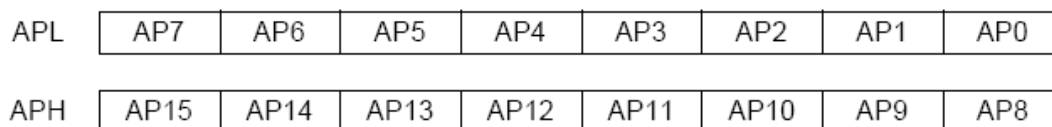

Figure 7. AP parameters

Table 8. Horizontal address range

Hex code				[AP] addresses per line
APH		APL		
0	0	0	0	0
0	0	0	1	1
↓	↓	↓	↓	↓
0	0	5	0	80
↓	↓	↓	↓	↓
F	F	F	E	$2^{16} - 2$
F	F	F	F	$2^{16} - 1$

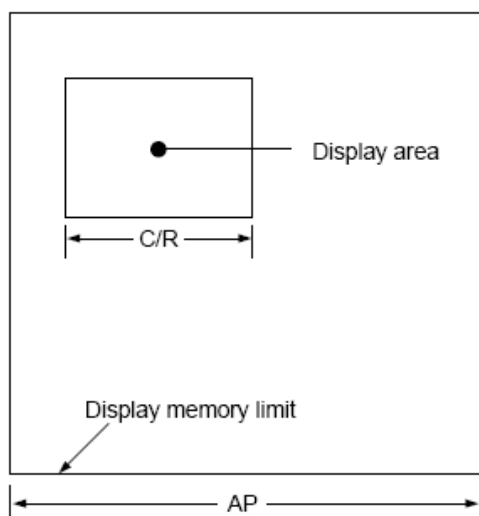

Figure 8. AP and C/R relationship

8.2.2. SLEEP IN

Places the system in standby mode. This command has no parameter bytes. At least one blank frame after receiving this command, the SED1335F halts all internal operations, including the oscillator, and enters the sleep state.

Blank data is sent to the X-drivers, and the Y-drivers have their bias supplies turned off by the YDIS signal. Using the YDIS signal to disable the Y-drivers guards against any spurious displays.

The internal registers of the SED1335 series maintain their values during the sleep state. The display memory control pins maintain their logic levels to ensure that the display memory is not corrupted.

The SED1335 series can be removed from the sleep state by sending the SYSTEM SET command with only the P1 parameter. The DISP ON command should be sent next to enable the display.

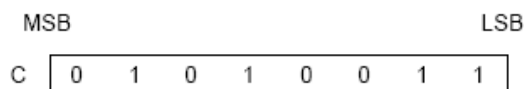

Figure 9. SLEEP IN instruction

1. The YDIS signal goes LOW between one and two frames after the SLEEP IN command is received. Since YDIS forces all display driver outputs to go to the deselected output voltage, YDIS can be used as a power-down signal for the LCD unit. This can be done by having YDIS turn off the relatively high-power LCD drive supplies at the same time as it blanks the display.
2. Since all internal clocks in the SED1335 series are halted while in the sleep state, a DC voltage will be applied to the LCD panel if the LCD drive supplies remain on. If reliability is a prime consideration, turn off the LCD drive supplies before issuing the SLEEP IN command.
3. Note that, although the bus lines become high impedance in the sleep state, pull-up or pull-down resistors on the bus will force these lines to a known state.

8.3. Display Control Commands

8.3.1. DISP ON/OFF

Turns the whole display on or off. The single-byte parameter enables and disables the cursor and layered screens, and sets the cursor and screen flash rates. The cursor can be set to flash over one character or over a whole line.

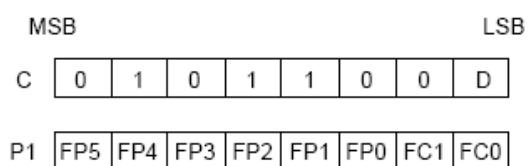

Figure 10. DISP ON/OFF parameters

8.3.1.1. D

Turns the display ON or OFF. The D bit takes precedence over the FP bits in the parameter.

D = 0: Display OFF

D = 1: Display ON

8.3.1.2. FC

Enables/disables the cursor and sets the flash rate. The cursor flashes with a 70% duty cycle (ON/OFF).

Table 9. Cursor flash rate selection

FC1	FC0	Cursor display	
0	0	OFF (blank)	
0	1	ON	No flashing
1	0		Flash at $f_{FR}/32$ Hz (approx. 2 Hz)
1	1		Flash at $f_{FR}/64$ Hz (approx. 1 Hz)

Note: As the MWRITE command always enables the cursor, the cursor position can be checked even when performing consecutive writes to display memory while the cursor is flashing.

8.3.1.3. FP

Each pair of bits in FP sets the attributes of one screen block, as follows.

The display attributes are as follows:

Table 10. Screen block attribute selection

FP1	FP0	First screen block (SAD1)	
FP3	FP2	Second screen block (SAD2, SAD4). See note.	
FP5	FP4	Third screen block (SAD3)	
0	0	OFF (blank)	
0	1	ON	No flashing
1	0		Flash at $f_{FR}/32$ Hz (approx. 2 Hz)
1	1		Flash at $f_{FR}/4$ Hz (approx. 16 Hz)

Note

If SAD4 is enabled by setting W/S to 1, FP3 and FP2 control both SAD2 and SAD4. The attributes of SAD2 and SAD4 cannot be set independently.

8.3.2. SCROLL

8.3.2.1. C

Sets the scroll start address and the number of lines per scroll block. Parameters P1 to P10 can be omitted if not

required. The parameters must be entered sequentially as shown in Figure 11.

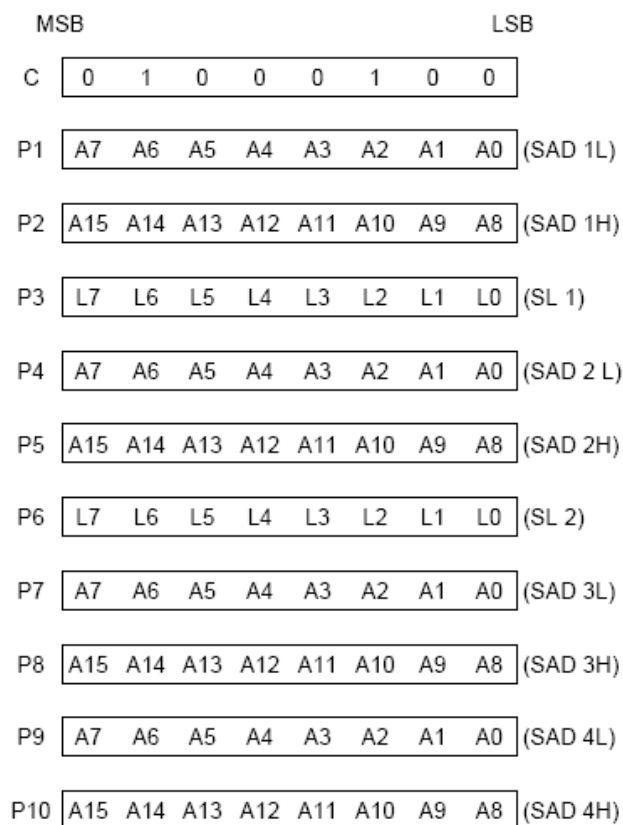

Figure 11. SCROLL instruction parameters

Note: Set parameters P9 and P10 only if both two-screen drive (W/S = 1) and two-layer configuration are selected. SAD4 is the fourth screen block display start address.

Table 11. Screen block start address selection

SL1, SL2									[SL] screen lines
HEX	L7	L6	L5	L4	L3	L2	L1	L0	
00	0	0	0	0	0	0	0	0	1
01	0	0	0	0	0	0	0	1	2
↓	↓	↓	↓	↓	↓	↓	↓	↓	↓
7F	0	1	1	1	1	1	1	1	128
↓	↓	↓	↓	↓	↓	↓	↓	↓	↓
FE	1	1	1	1	1	1	1	0	255
FF	1	1	1	1	1	1	1	1	256

8.3.2.2. SL1, SL2

SL1 and SL2 set the number of lines per scrolling screen. The number of lines is SL1 or SL2 plus one. The relation-

ship between SAD, SL and the display mode is described below.

Table 12. Text display mode

W/S	Screen	First Layer	Second Layer
0	First screen block	SAD1	SAD2
	Second screen block	SL1	SL2
	Third screen block (partitioned screen)	SAD3 (see note 1) Set both SL1 and SL2 to L/F + 1 if not using a partitioned screen.	
	Screen configuration example:		
	<p>The diagram illustrates a screen configuration with two layers, Layer 1 and Layer 2. Layer 1 contains 'Character display page 1' and 'Character display page 3'. Layer 2 contains 'Graphics display page 2'. Address pointers SAD1, SAD2, and SAD3 are shown on the left, pointing to the start of the first screen block, the second screen block, and the partitioned screen block respectively. SL1 and SL2 are shown on the right, indicating the number of lines for the first and second screen blocks. A dot on the right side of the diagram indicates the position of the graphics display page 2.</p>		

Table 12. Text display mode (continued)

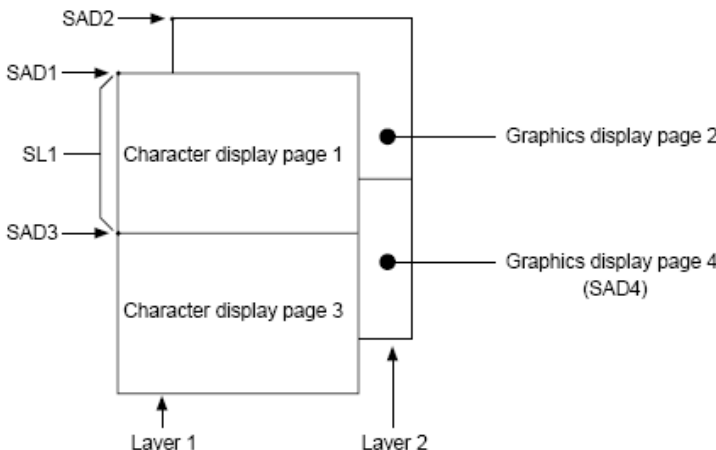
W/S	Screen	First Layer	Second Layer
1	Upper screen	SAD1 SL1	SAD2 SL2
	Lower screen	SAD3 (See note 2.)	SAD4 (See note 2.)
	Set both SL1 and SL2 to $((L/F) / 2 + 1)$.		
<p style="text-align: center;">Screen configuration example:</p>  <p>The diagram illustrates a screen configuration across two layers. On the left, a vertical stack of pages is shown: 'Character display page 1' at the top, followed by 'Character display page 3' at the bottom. Arrows point to these pages from labels 'SAD1', 'SL1', and 'SAD3' on the left. Below the stack, an arrow labeled 'Layer 1' points upwards. On the right, a vertical stack of graphics display pages is shown: 'Graphics display page 2' at the top, followed by 'Graphics display page 4 (SAD4)' at the bottom. An arrow labeled 'Layer 2' points upwards from below. Lines connect 'SAD2' to 'Character display page 1' and 'SAD2' to 'Graphics display page 2'. Another line connects 'SAD3' to 'Graphics display page 4 (SAD4)'.</p>			

Notes:

1. SAD3 has the same value as either SAD1 or SAD2, whichever has the least number of lines (set by SL1 and SL2).
2. Since the parameters corresponding to SL3 and SL4 are fixed by L/F, they do not have to be set in this mode.

Table 13. Graphics display mode

W/S	Screen	First Layer	Second Layer	Third Layer
0	Two-layer composition	SAD1 SL1	SAD2 SL2	
	Upper screen	SAD3 (see note 3.) Set both SL1 and SL2 to L/F + 1 if not using a partitioned screen		
	Screen configuration example:			
0	Three-layer configuration	SAD1 SL1 = L/F + 1	SAD2 SL2 = L/F + 1	SAD3 —
	Screen configuration example:			

Table 13. Graphics display mode (continued)

W/S	Screen	First Layer	Second Layer	Third Layer
1	Upper screen	SAD1 SL1	SAD2 SL2	—
	Lower screen	SAD3 (See note 2.)	SAD4 (See note 2.)	—
	Set both SL1 and SL2 to $((L/F) / 2 + 1)$. Screen configuration example (See note 3.):			

Notes:

1. SAD3 has the same value as either SAD1 or SAD2, whichever has the least number of lines (set by SL1 and SL2).
2. Since the parameters corresponding to SL3 and SL4 are fixed by L/F, they do not have to be set.
3. If, and only if, W/S = 1, the differences between SL1 and $(L/F + 1) / 2$, and between SL2 and $(L/F + 1) / 2$, are blanked.

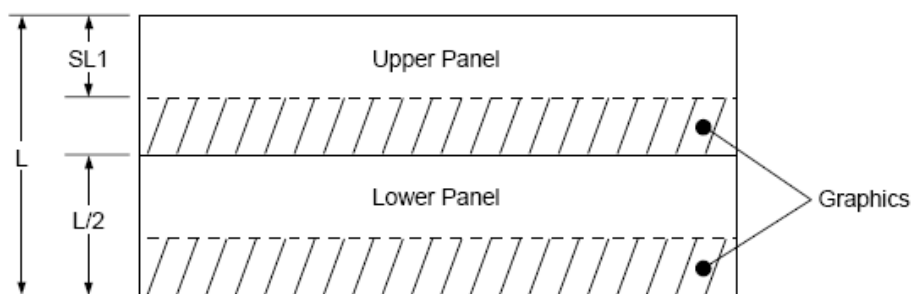

Figure 12. Two-panel display height

8.3.3. CSRFORM

Sets the cursor size and shape. Although the cursor is normally only used in text displays, it may also be used in graphics displays when displaying special characters.

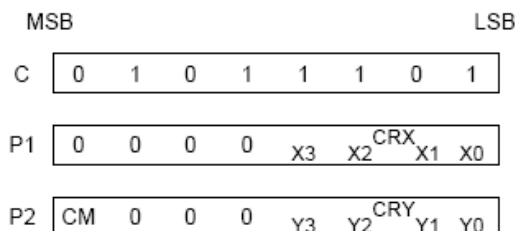

Figure 13. CSRFORM parameter bytes

8.3.3.1. CRX

Sets the horizontal size of the cursor from the character origin. CRX is equal to the cursor size less one. CRX must be less than or equal to FX.

Table 14. Horizontal cursor size selection

CRX					[CRX] cursor width (pixels)
HEX	X3	X2	X1	X0	
0	0	0	0	0	1
1	0	0	0	1	2
↓	↓	↓	↓	↓	↓
4	0	1	0	0	9
↓	↓	↓	↓	↓	↓
E	1	1	1	0	15
F	1	1	1	1	16

8.3.3.2. CRY

Sets the location of an underscored cursor in lines, from the character origin. When using a block cursor, CRY sets the vertical size of the cursor from the character origin. CRY is equal to the number of lines less one.

Table 15. Cursor height selection

CRY					[CRY] cursor height (lines)
HEX	Y3	Y2	Y1	Y0	
0	0	0	0	0	Illegal
1	0	0	0	1	2
↓	↓	↓	↓	↓	↓
8	1	0	0	0	9
↓	↓	↓	↓	↓	↓
E	1	1	1	0	15
F	1	1	1	1	16

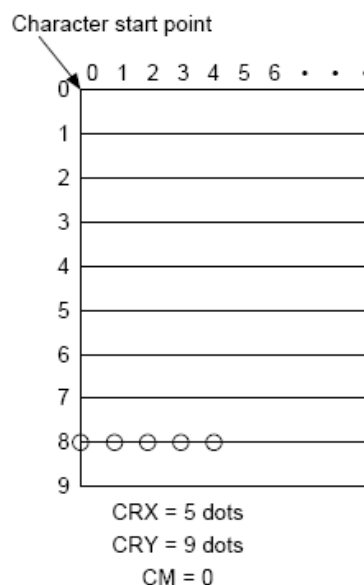

Figure 14. Cursor size and position

8.3.3.3. CM

Sets the cursor shape. Always set CM to 1 when in graphics mode.

CM = 0: Underscore cursor

CM = 1: Block cursor

8.3.4. CSRDIR

Sets the direction of automatic cursor increment. The cursor can move left or right one character, or up or down by the number of bytes specified by the address pitch, A. When reading from and writing to display memory, the automatic cursor increment controls the display memory address increment on each read or write.

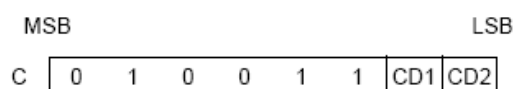

Figure 15. CSRDIR parameters

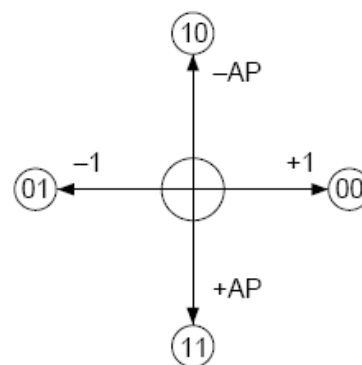

Figure 16. Cursor direction

Table 16. Cursor shift direction

C	CD1	CD0	Shift direction
4CH	0	0	Right
4DH	0	1	Left
4EH	1	0	Up
4FH	1	1	Down

Note: Since the cursor moves in address units even if FX ≥ 9, the cursor address increment must be preset for movement in character units. See Section 9.3.

8.3.5. OVLAY

Selects layered screen composition and screen text/ graphics mode.

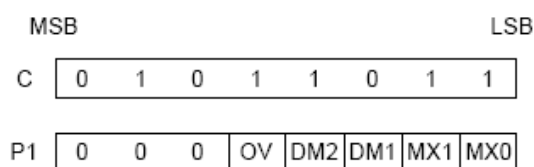

Figure 17. OVLAY parameters

8.3.5.1. MX0, MX1

MX0 and MX1 set the layered screen composition method, which can be either OR, AND, Exclusive-OR or Priority-OR. Since the screen composition is organized in layers and not by screen blocks, when using a layer divided into two screen blocks, different composition methods cannot be specified for the individual screen blocks.

The Priority-OR mode is the same as the OR mode unless flashing of individual screens is used.

Table 17. Composition method selection

MX1	MX0	Function	Composition Method	Applications
0	0	$L1 \cup L2 \cup L3$	OR	Underlining, rules, mixed text and graphics
0	1	$(L1 \oplus L2) \cup L3$	Exclusive-OR	Inverted characters, flashing regions, underlining
1	0	$(L1 \cap L2) \cup L3$	AND	Simple animation, three-dimensional appearance
1	1	$L1 > L2 > L3$	Priority-OR	

Notes:

- L1: First layer (text or graphics). If text is selected, layer L3 cannot be used.
- L2: Second layer (graphics only)
- L3: Third layer (graphics only)

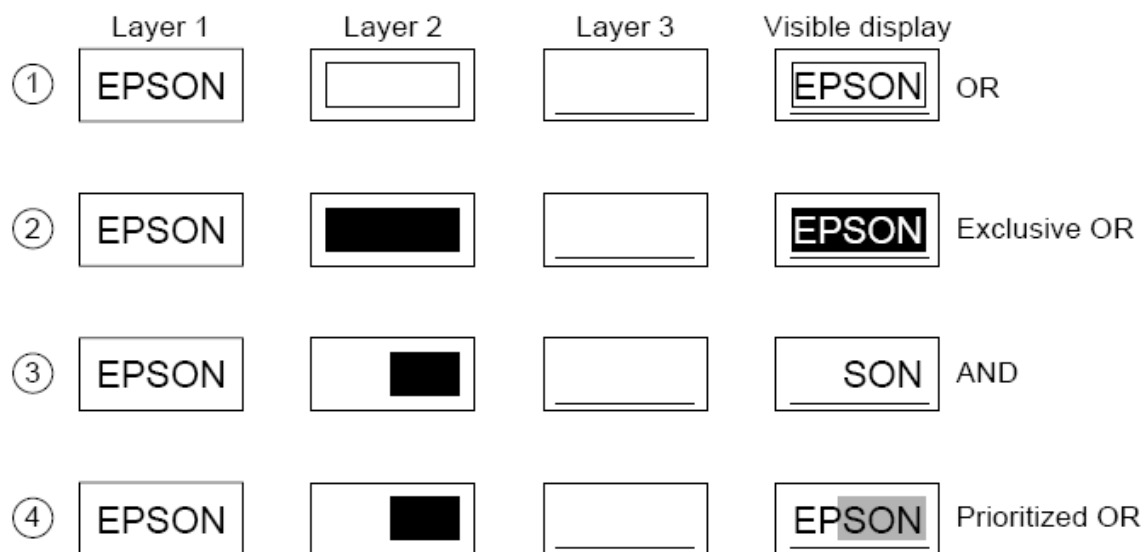

Figure 18. Combined layer display

Notes:

- L1: Not flashing
- L2: Flashing at 1 Hz
- L3: Flashing at 2 Hz

8.3.5.2. DM1, DM2

DM1 and DM2 specify the display mode of screen blocks 1 and 3, respectively.

DM1/2 = 0: Text mode

DM1/2 = 1: Graphics mode

Note 1: Screen blocks 2 and 4 can only display graphics.

Note 2: DM1 and DM2 must be the same, regardless of the setting of W/S.

8.3.5.3. OV

Specifies two- or three-layer composition in graphics mode.

OV = 0: Two-layer composition

OV = 1: Three-layer composition

Set OV to 0 for mixed text and graphics mode.

8.3.6. CGRAM ADR

Specifies the CG RAM start address.

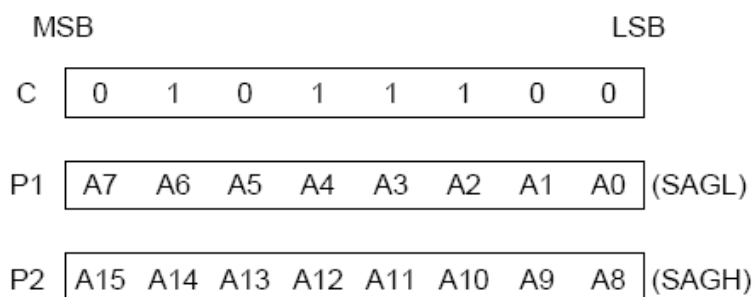

Figure 19. CGRAM ADR parameters

Note

See section 10 for information on the SAG parameters.

8.3.7. HDOT SCR

While the SCROLL command only allows scrolling by characters, HDOT SCR allows the screen to be scrolled horizontally by pixels. HDOT SCR cannot be used on individual layers.

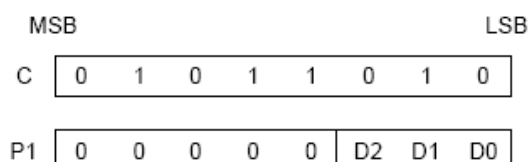

Figure 20. HDOT SCR parameters

8.3.7.1. D0 to D2

Specifies the number of pixels to scroll. The C/R parameter has to be set to one more than the number of horizontal characters before using HDOT SCR. Smooth scrolling can be simulated if the controlling microprocessor repeatedly issues the HDOT SCR command to the SED1335 series. See Section 9.5 for more information on scrolling the display.

Table 18. Scroll step selection (continued)

HEX	P1			Number of pixels to scroll
	D2	D1	D0	
00	0	0	0	0
01	0	0	1	1
02	0	1	0	2
↓	↓	↓	↓	↓
06	1	1	0	6
07	1	1	1	7

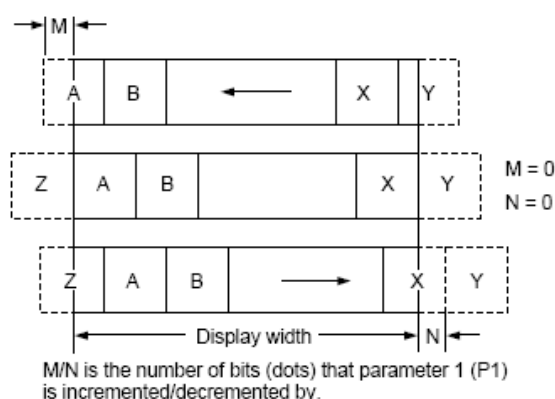

Figure 21. Horizontal scrolling

8.4. Drawing Control Commands

8.4.1. CSRW

The 16-bit cursor address register contains the display memory address of the data at the cursor position as shown in Figure 22.

Note that the microprocessor cannot directly access the display memory.

The MREAD and MWRITE commands use the address in this register.

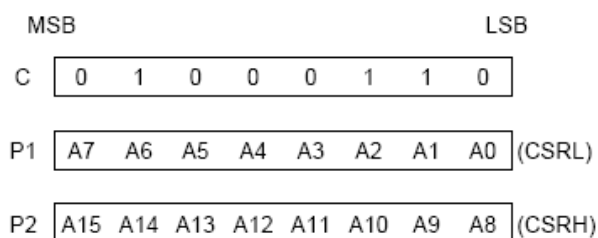

Figure 22. CSRW parameters

The cursor address register can only be modified by the CSRW command, and by the automatic increment after an MREAD or MWRITE command. It is not affected by display scrolling.

If a new address is not set, display memory accesses will be from the last set address or the address after previous automatic increments.

8.4.2. CSRR

Reads from the cursor address register. After issuing the command, the data read address is read twice, for the low byte and then the high byte of the register.

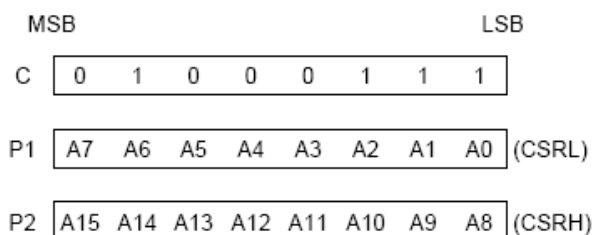

Figure 23. CSRR parameters

8.5. Memory Control Commands

8.5.1. MWRITE

The microprocessor may write a sequence of data bytes to display memory by issuing the MREAD command and then writing the bytes to the SED1335 series. There is no need for further MWRITE commands or for the micro-

processor to update the cursor address register after each byte as the cursor address is automatically incremented by the amount set with CSRDIR, in preparation for the next data write.

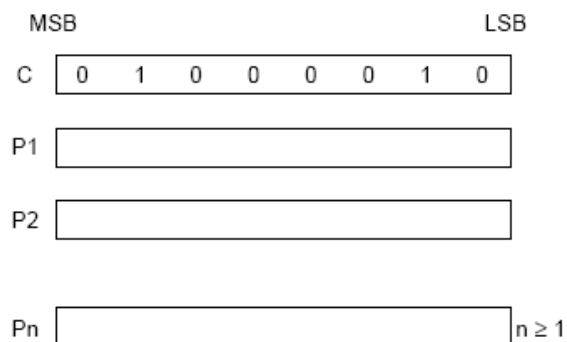

Figure 24. MWRITE parameters

Note:

P1, P2, ..., Pn: display data.

8.5.2. MREAD

Puts the SED1335 series into the data output state. Each time the microprocessor reads the buffer, the cursor address is incremented by the amount set by CSRDIR and the next data byte fetched from memory, so a sequence of

data bytes may be read without further MREAD commands or by updating the cursor address register. If the cursor is displayed, the read data will be from two positions ahead of the cursor.



Figure 25. MREAD parameters

9. DISPLAY CONTROL FUNCTIONS

9.1. Character Configuration

The origin of each character bitmap is in the top left corner as shown in Figure 29. Adjacent bits in each byte are horizontally adjacent in the corresponding character image.

Although the size of the bitmap is fixed by the character generator, the actual displayed size of the character field can be varied in both dimensions.

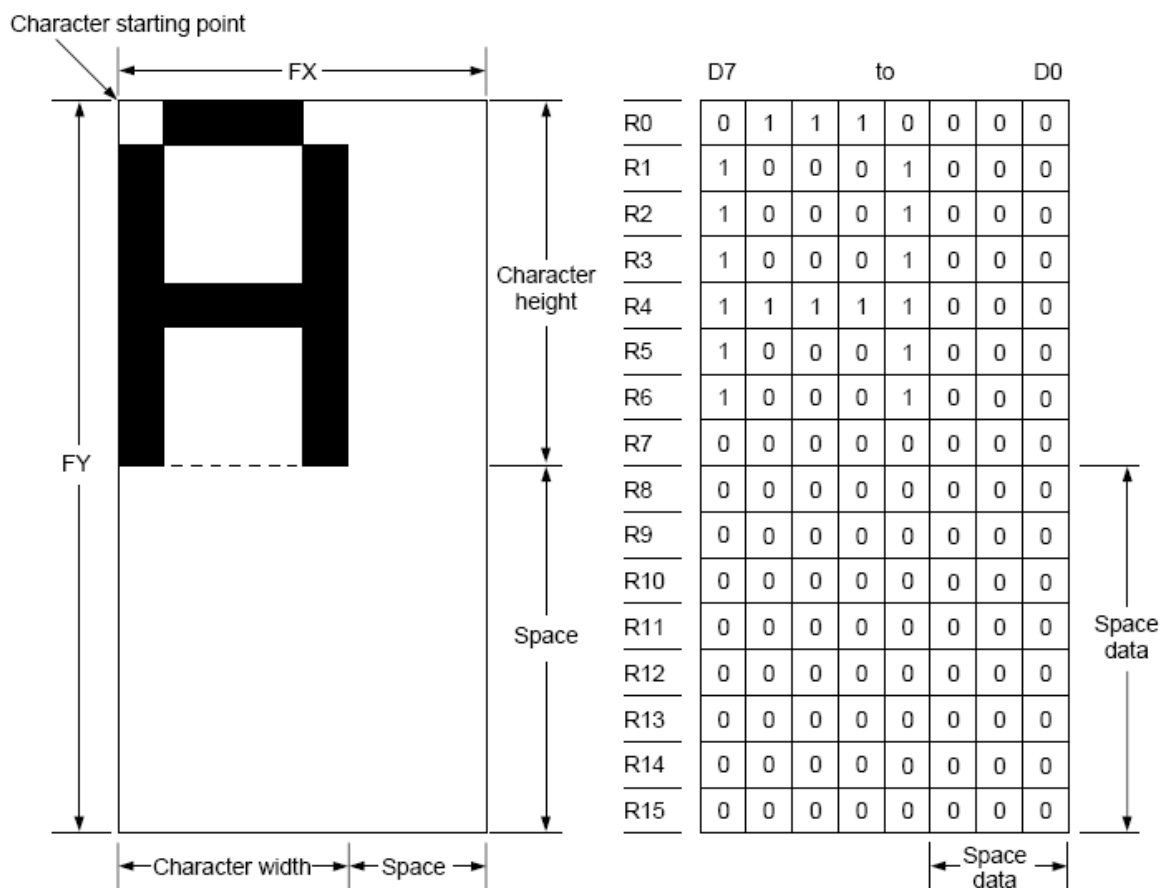

Figure 26. Example of character display ($[FX] \leq 8$) and generator bitmap

If the area outside the character bitmap contains only zeros, the displayed character size can easily be increased by increasing FX and FY, as the zeros ensure that the extra space between displayed characters is blank.

The displayed character width can be set to any value up to 16 even if each horizontal row of the bitmap is two bytes wide.

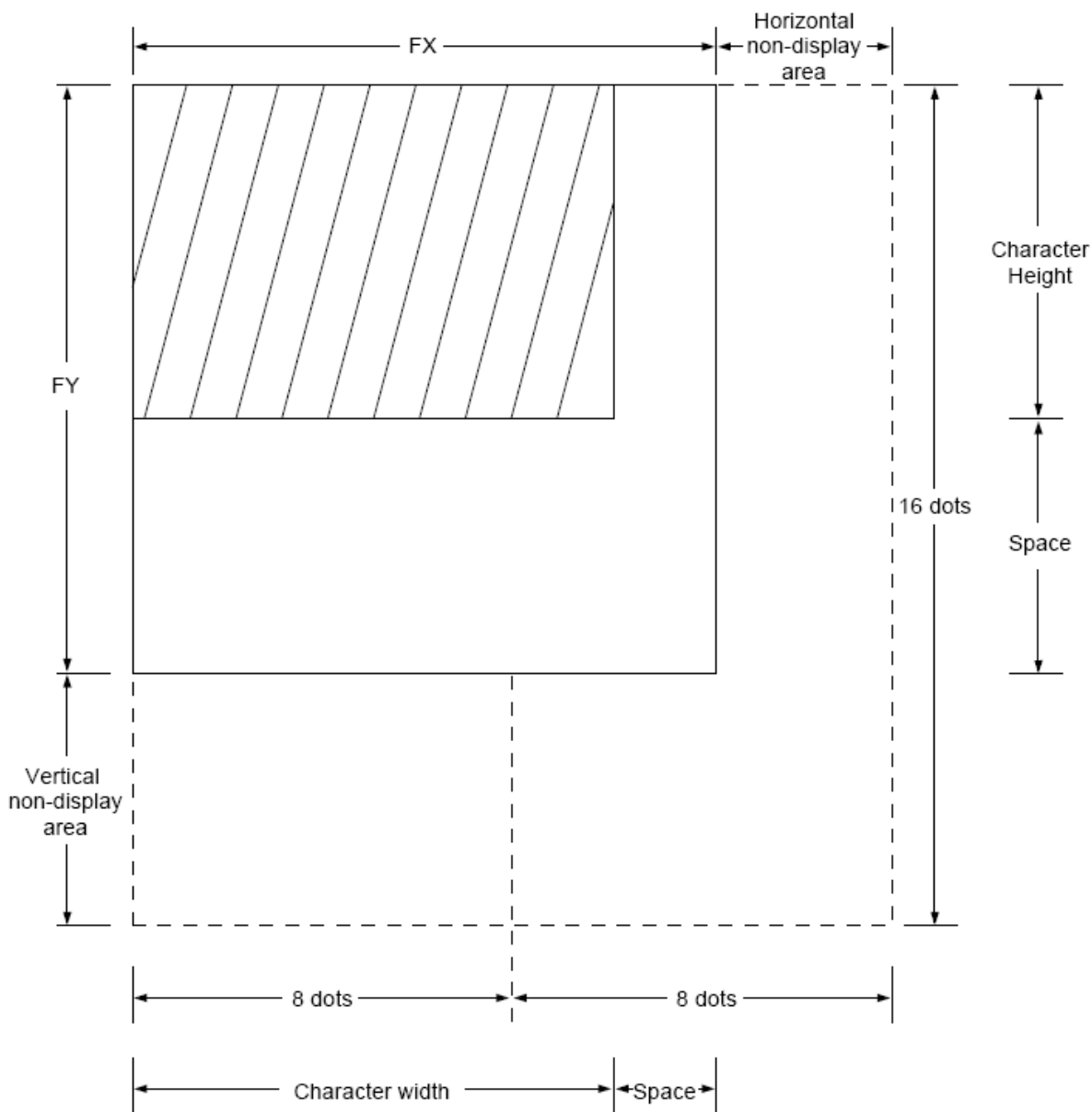

Figure 27. Character width greater than one byte wide ($[FX] = 9$)

Note: The SED1335 series does not automatically insert spaces between characters. If the displayed character size is 8 pixels or less and the space between character origins is nine pixels or more, the bitmap must use two bytes per row, even though the character image requires only one.

9.2. Screen Configuration

9.2.1. Screen configuration

The basic screen configuration of the SED1335 series is as a single text screen or as overlapping text and graphics screens. The graphics screen uses eight times as much display memory as the text screen.

Figure 28 shows the relationship between the virtual screens and the physical screen.

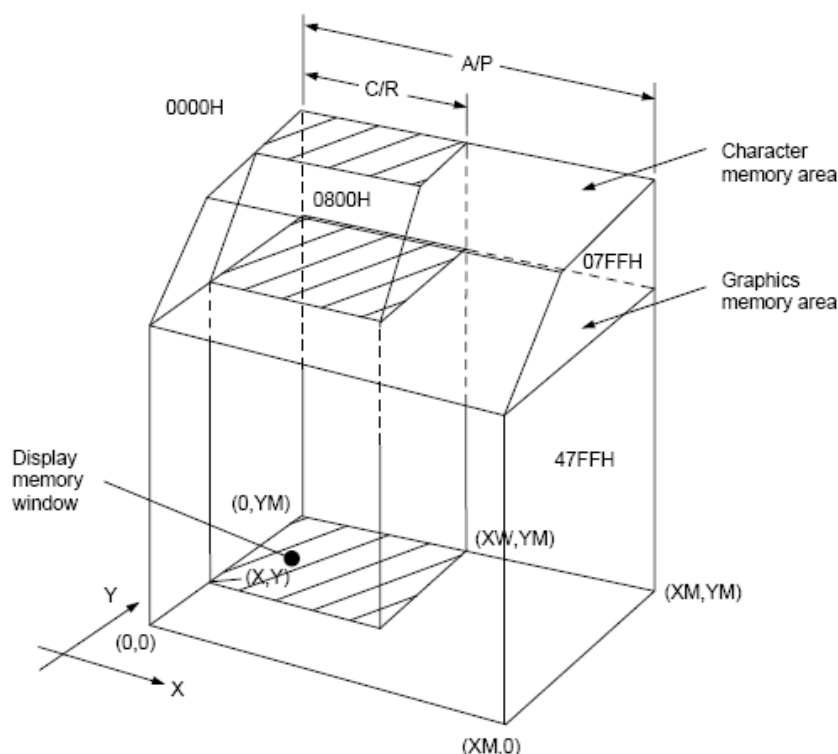

Figure 28. Virtual and physical screen relationship

9.2.2. Display address scanning

The SED1335 series scans the display memory in the same way as a raster scan CRT screen. Each row is scanned from left to right until the address range equals C/R. Rows are scanned from top to bottom.

In graphics mode, at the start of each line, the address counter is set to the address at the start of the previous line plus the address pitch, AP.

In text mode, the address counter is set to the same start address, and the same character data is read, for each row in the character bitmap. However, a new row of the character generator output is used each time. Once all the rows in the character bitmap have been displayed, the address counter is set to the start address plus AP and the next line of text is displayed.

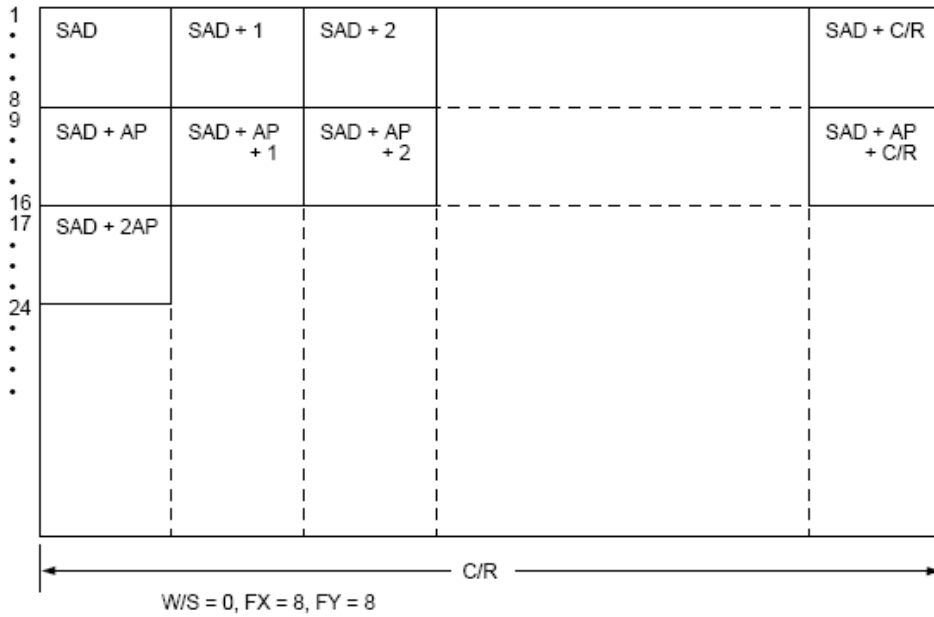

Figure 29. Character position parameters

Note: One byte of display memory corresponds to one character.

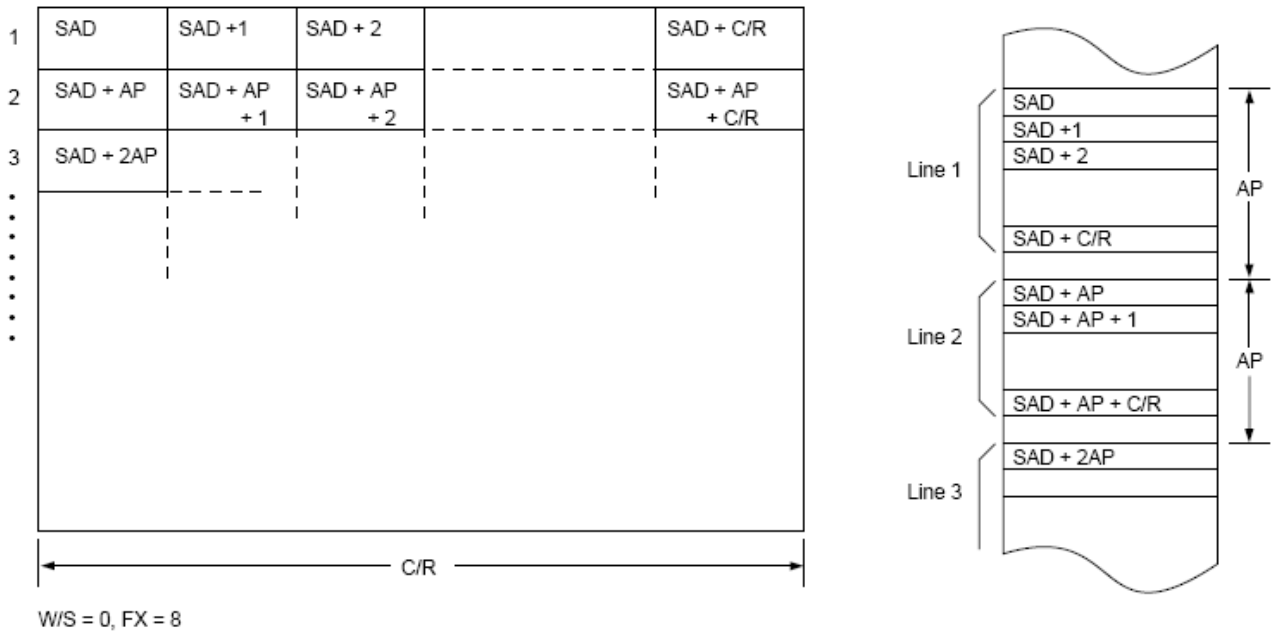

Figure 30. Character parameters vs. memory

Note: One bit of display memory corresponds to one pixel.

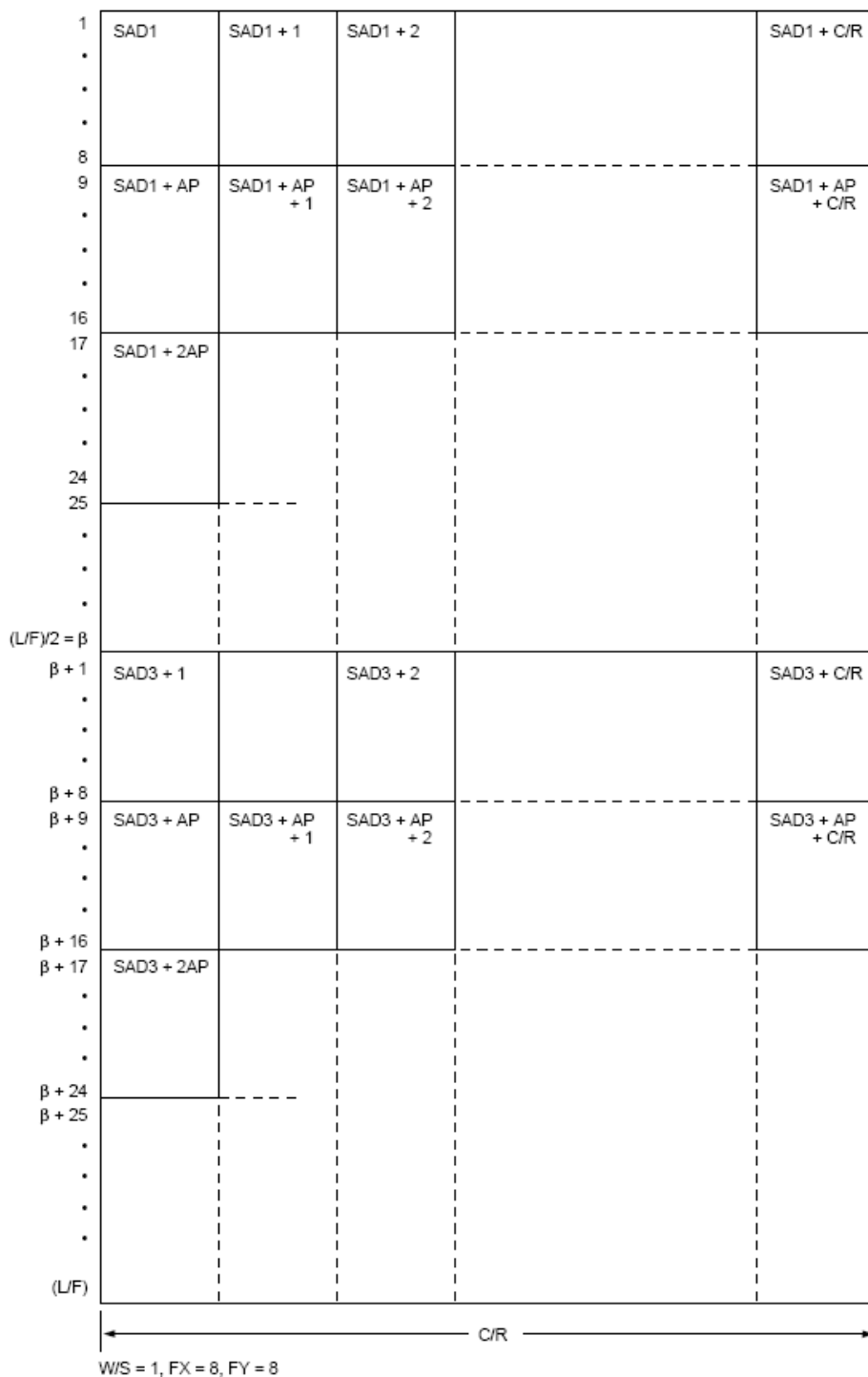

Figure 31. Two-panel display address indexing

Note

In two-panel drive, the SED1335 series reads line 1 and line $\beta + 1$ as one cycle. The upper and lower panels are thus read alternately, one line at a time.

9.2.3. Display scan timing

Figure 32 shows the basic timing of the SED1335 series. One display memory read cycle takes nine periods of the system clock, ϕ_0 (f_{osc}). This cycle repeats $(C/R + 1)$ times per display line.

When reading, the display memory pauses at the end of each line for $(TC/R - C/R)$ display memory read cycles,

though the LCD drive signals are still generated. TC/R may be set to any value within the constraints imposed by C/R , f_{osc} , f_{FR} , and the size of the LCD panel, and it may be used to fine tune the frame frequency. The microprocessor may also use this pause to access the display memory data.

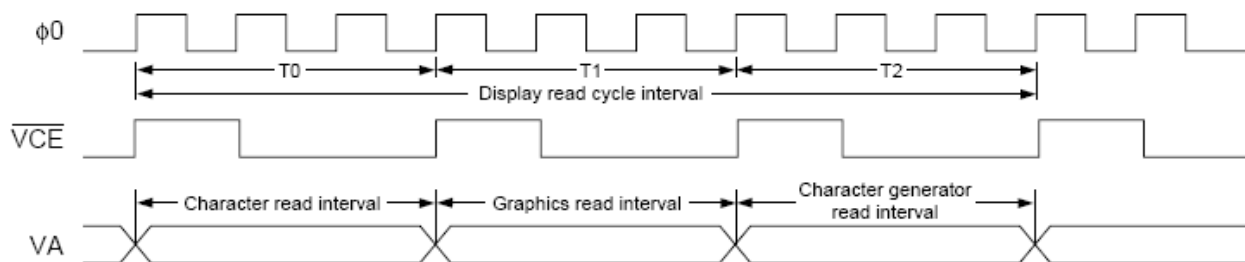

Figure 32. Display memory basic read cycle

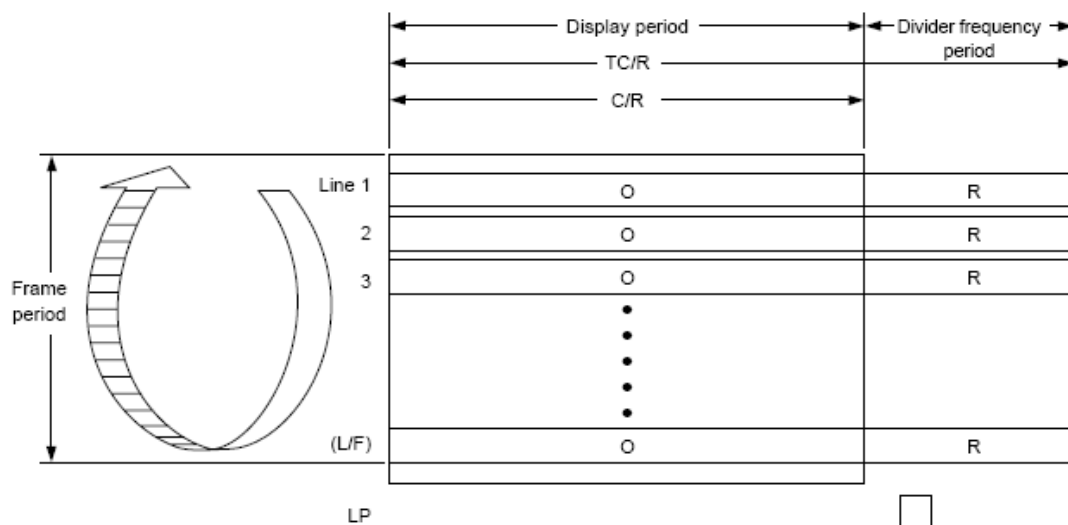

Figure 33. Relationship between TC/R and C/R

Note: The divider adjustment interval (R) applies to both the upper and lower screens even if $W/S = 1$. In this case, LP is active only at the end of the lower screen's display interval.

9.3. Cursor Control

9.3.1. Cursor register function

The SED1335 series cursor address register functions as both the displayed cursor position address register and the display memory access address register. When accessing display memory outside the actual screen memory, the address register must be saved before accessing the memory and restored after memory access is complete.

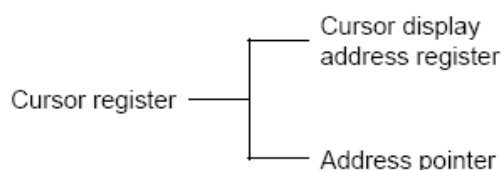

Figure 34. Cursor addressing

Note that the cursor may disappear from the display if the cursor address remains outside the displayed screen memory for more than a few hundred milliseconds.

9.3.2. Cursor movement

On each memory access, the cursor address register changes by the amount previously specified with CSRDIR, automatically moving the cursor to the desired location.

9.3.3. Cursor display layers

Although the SED1335 series can display up to three layers, the cursor is displayed in only one of these layers:
 Two-layer configuration: First layer (L1)
 Three-layer configuration: Third layer (L3)
 The cursor will not be displayed if it is moved outside the memory for its layer. Layers may be swapped or the cursor layer moved within the display memory if it is necessary to display the cursor on a layer other than the present cursor layer.

Although the cursor is normally displayed for character data, the SED1335 series may also display a dummy cursor for graphical characters. This is only possible if the graphics screen is displayed, the text screen is turned off and the microprocessor generates the cursor control address.

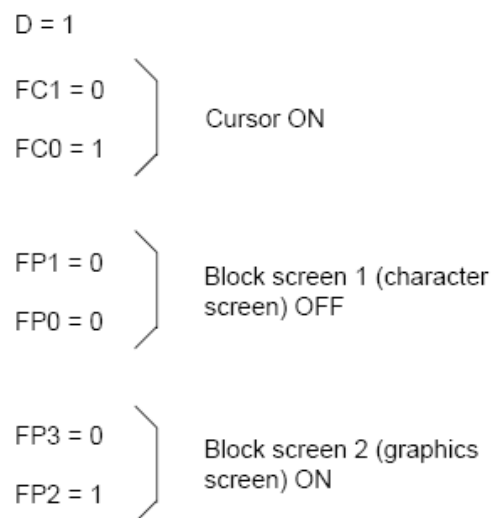

Figure 35. Cursor display layers

Consider the example of displaying Chinese characters on a graphics screen. To write the display data, the cursor address is set to the second screen block, but the cursor is not displayed. To display the cursor, the cursor address is set to an address within the blank text screen block. Since the automatic cursor increment is in address units, not character units, the controlling microprocessor must set the cursor address register when moving the cursor over the graphical characters.

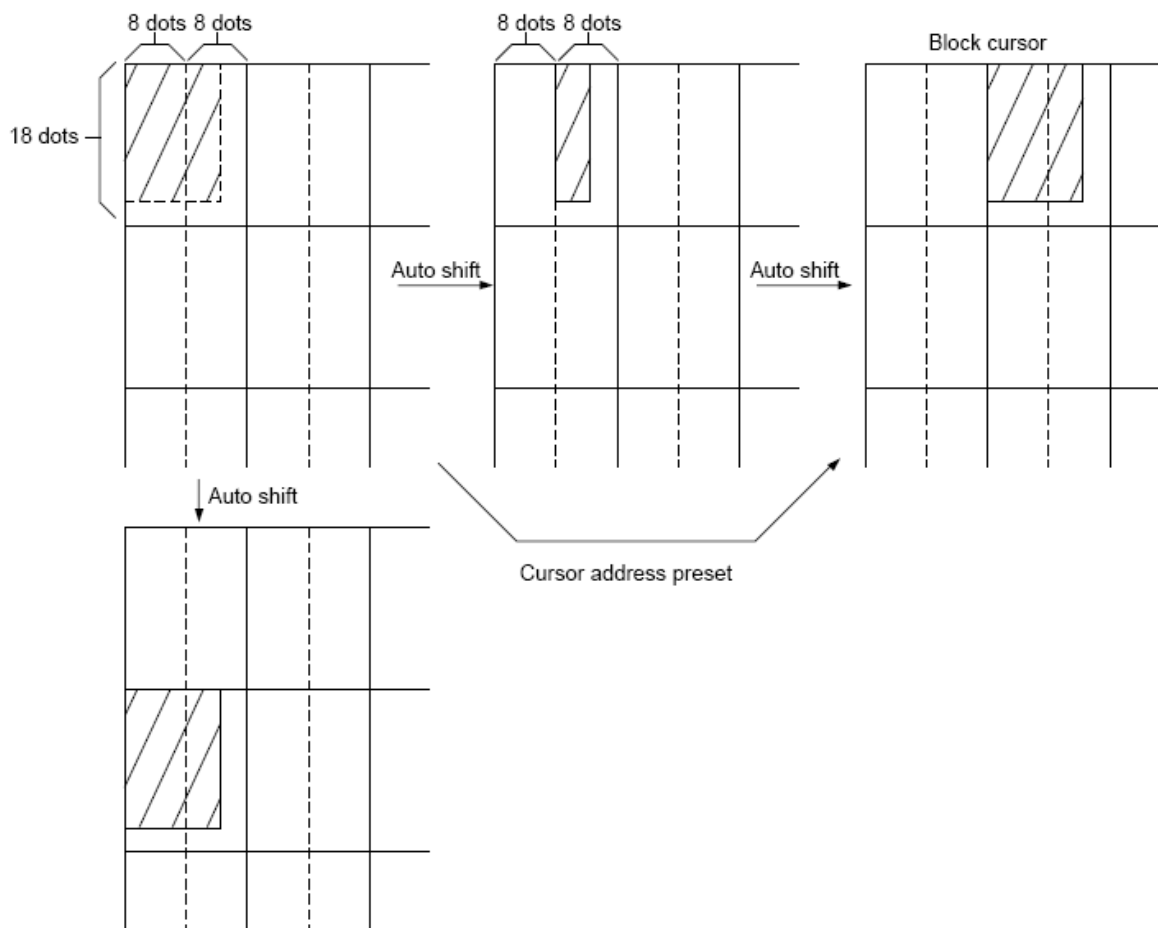

Figure 36. Cursor movement

If no text screen is displayed, only a bar cursor can be displayed at the cursor address.
 If the first layer is a mixed text and graphics screen and the cursor shape is set to a block cursor, the SED1335 series

automatically decides which cursor shape to display. On the text screen it displays a block cursor, and on the graphics screen, a bar cursor.

9.4. Memory to Display Relationship

The SED1335 series supports virtual screens that are larger than the physical size of the LCD panel address range, C/R. A layer of the SED1335 series can be considered as a window in the larger virtual screen held in display memory. This window can be divided into two

blocks, with each block able to display a different part of the virtual screen.

This enables, for example, one block to dynamically scroll through a data area while the other acts as a static message display area. See Figure 37 and 38.



Figure 37. Display layers and memory

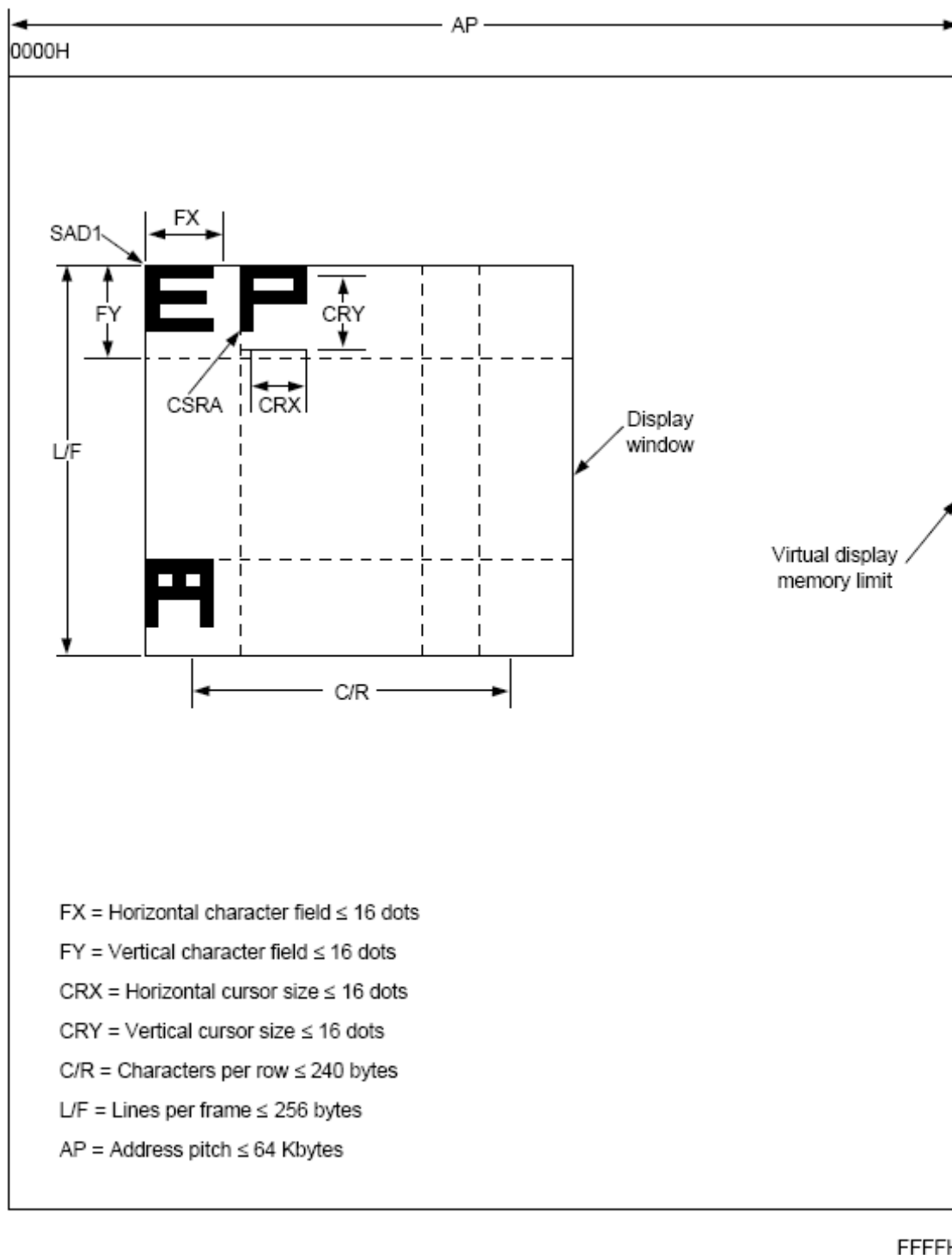

Figure 38. Display window and memory

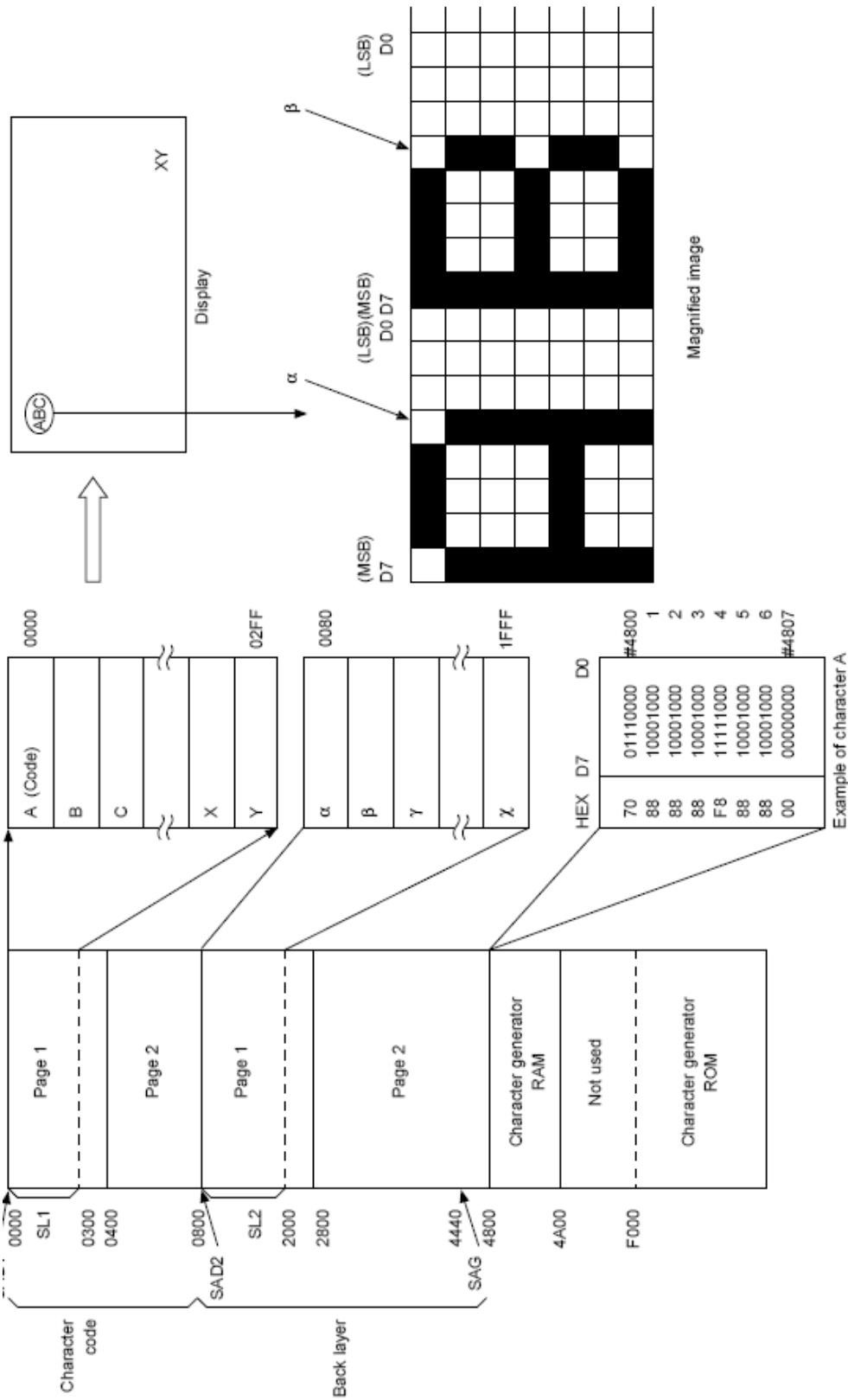

Figure 39. Memory map and magnified characters

9.5. Scrolling

The controlling microprocessor can set the SED1335 series scrolling modes by overwriting the scroll address registers SAD1 to SAD4, and by directly setting the scrolling mode and scrolling rate.

Since the SED1335 series does not automatically erase the bottom line, it must be erased with blanking data changing the scroll address register.

9.5.1. On-page scrolling

The normal method of scrolling within a page is to move the whole display up one line and erase the bottom line.

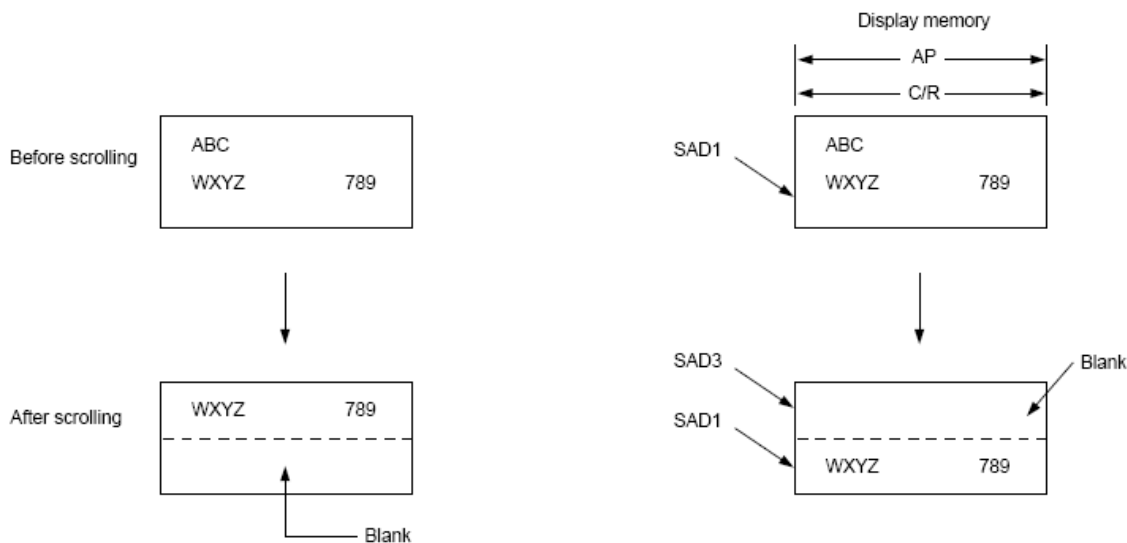

Figure 40. On-page scrolling

9.5.2. Inter-page scrolling

Scrolling between pages and page switching can be performed only if the display memory capacity is greater than one screen.

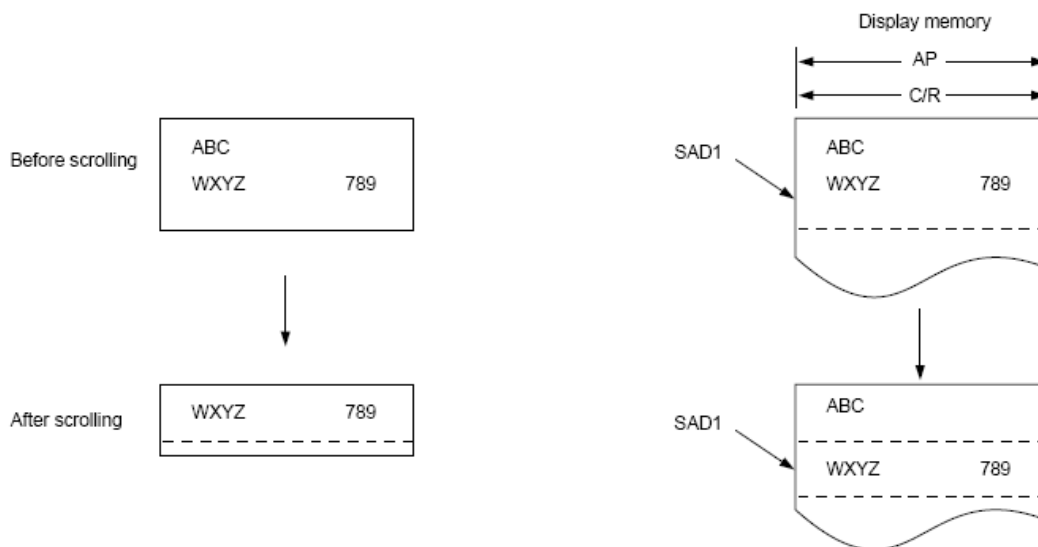

Figure 41. Inter-page scrolling

9.5.3. Horizontal scrolling

The display can be scrolled horizontally in one-character units, regardless of the display memory capacity.

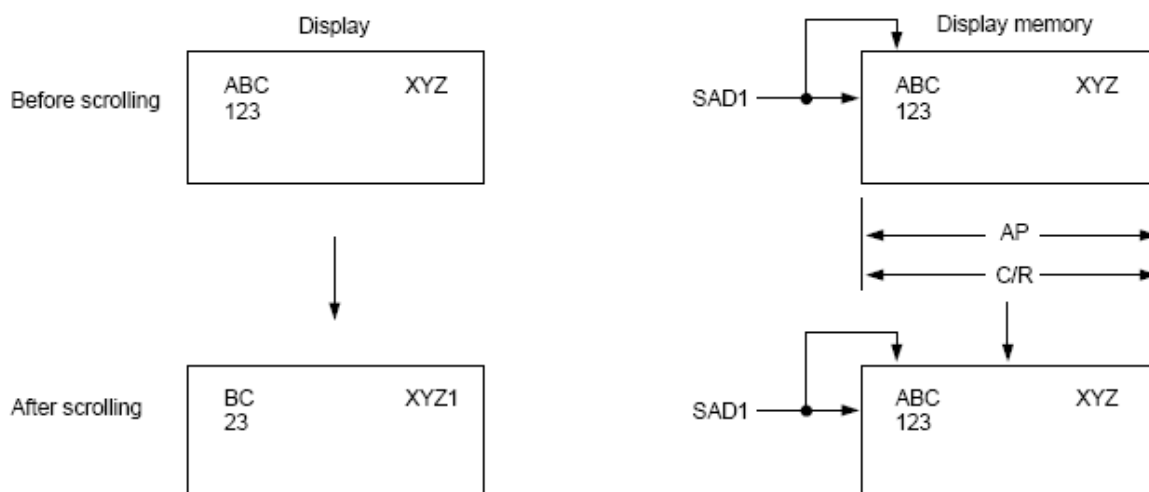

Figure 42. Horizontal wraparound scrolling

9.5.4. Bidirectional scrolling

Bidirectional scrolling can be performed only if the display memory is larger than the physical screen both horizontally and vertically. Although scrolling is normally done in single-character units, the HDOT SCR

command can be used to scroll horizontally in pixel units. Single-pixel scrolling both horizontally and vertically can be performed by using the SCROLL and HDOT SCR commands. See Section 16.4

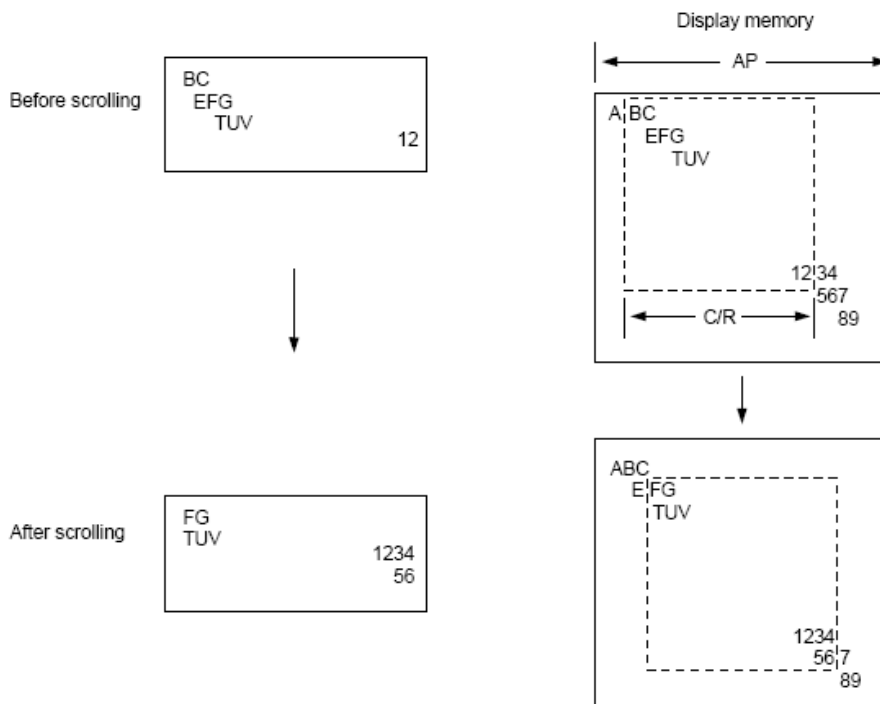

Figure 43. Bidirectional scrolling

9.5.5. Scroll units

Tale 19. Scroll units

Mode	Vertical	Horizontal
Text	Characters	Pixels or characters
Graphics	Pixels	Pixels

Note that in a divided screen, each block cannot be independently scrolled horizontally in pixel units.

10. CHARACTER GENERATOR

10.1. CG Characteristics

10.1.1. Internal character generator

The internal character generator is recommended for minimum system configurations containing a SED1335 series, display RAM, LCD panel, single-chip microprocessor and power supply. Since the internal character generator uses a CMOS mask ROM, it is also recommended for low-power applications.

- 5 × 7-pixel font (See Section 17.)
- 160 JIS standard characters
- Can be mixed with character generator RAM (maximum of 64 CG RAM characters)
- Can be automatically spaced out up to 8 × 16 pixels

10.1.2. External character generator ROM

The external CG ROM can be used when fonts other than those in the internal ROM are needed. Data is stored in the external ROM in the same format used in the internal ROM. (See Section 10.3.)

- Up to 8 × 8-pixel characters (M2 = 0) or 8 × 16-pixel characters (M2 = 1)
- Up to 256 characters (192 if used together with the internal ROM)
- Mapped into the display memory address space at F000H to F7FFH (M2 = 0) or F000H to FFFFH (M2 = 1)
- Characters can be up to 8 × 16-pixels; however, excess bits must be set to zero.

10.1.3. Character generator RAM

The user can freely use the character generator RAM for storing graphics characters. The character generator RAM can be mapped by the microprocessor anywhere in display memory, allowing effective use of unused address space.

- Up to 8 × 8-pixel characters (M2 = 0) or 8 × 16 characters (M2 = 1)
- Up to 256 characters if mapped at F000H to FFFFH (64 if used together with character generator ROM)
- Can be mapped anywhere in display memory address space if used with the character generator ROM
- Mapped into the display memory address space at F000H to F7FFH if not used with the character generator ROM (more than 64 characters are in the CG RAM). Set SAG0 to F000H and M1 to zero when defining characters number 193 upwards.

10.2. CG Memory Allocation

Since the SED1335 series uses 8-bit character codes, it can handle no more than 256 characters at a time. However, if a wider range of characters is required, character

generator memory can be bank-switched using the CGRAM ADR command.

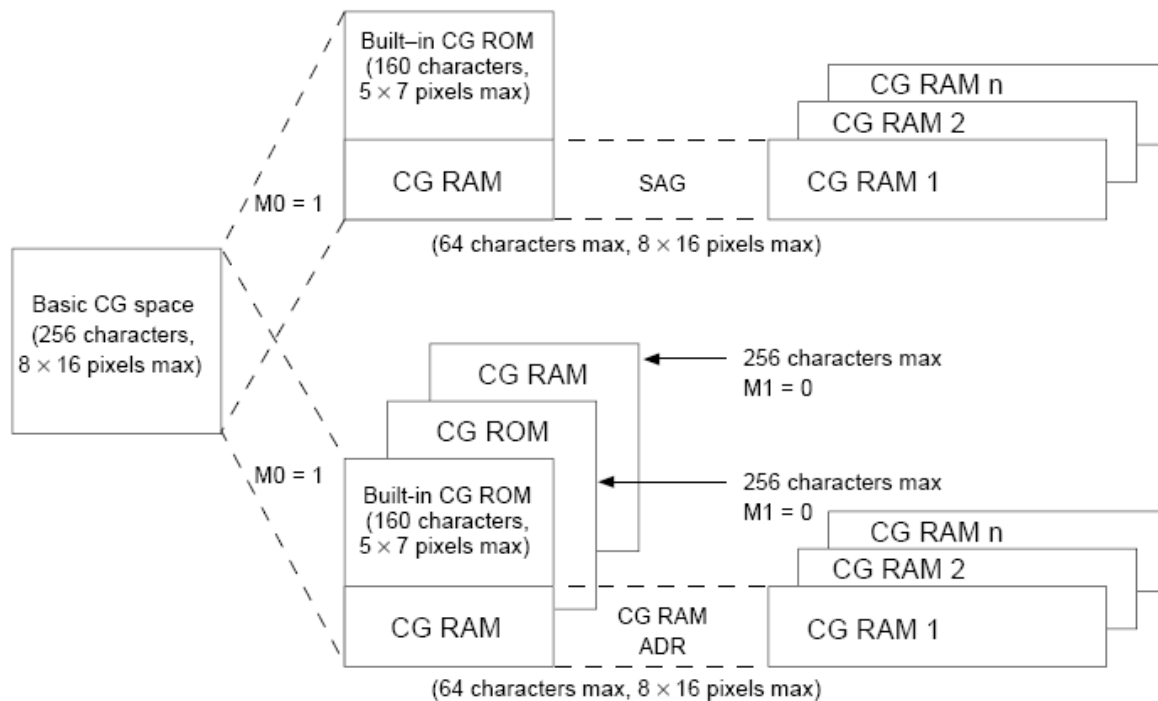

Figure 44. Internal and external character mapping

Note that there can be no more than 64 characters per bank.

Table 20. Character mapping

Item	Parameter	Remarks
Internal/external character generator selection	M0	
Character field height	1 to 8 pixels	M2 = 0
	9 to 16 pixels	M2 = 1
	Greater than 16 pixels	Graphics mode (8 bits × 1 line)
Internal CG ROM/RAM select External CG ROM/RAM select	Automatic	Determined by the character code
CG RAM bit 6 correction	M1	
CG RAM data storage address	Specified with CG RAM ADR command	Can be moved anywhere in the display memory address space
External CG ROM address	192 characters or less	Other than the area of Figure 49
	More than 192 characters	Set SAG to F000H and overlay SAG and the CG ROM table

10.3. Setting the Character Generator Address

The CG RAM addresses in the VRAM address space are not mapped directly from the address in the SAG register. The data to be displayed is at a CG RAM address

calculated from SAG + character code + ROW select address. This mapping is shown in Table 21 and 22.

Table 21. Character fonts, number of lines ≤ 8 ($M2 = 0, M1 = 0$)

SAG	A15	A14	A13	A12	A11	A10	A9	A8	A7	A6	A5	A4	A3	A2	A1	A0
Character code	0	0	0	0	0	D7	D6	D5	D4	D3	D2	D1	D0	0	0	0
+ROW select address	0	0	0	0	0	0	0	0	0	0	0	0	0	R2	R1	R0
CG RAM address	VA15	VA14	VA13	VA12	VA11	VA10	VA9	VA8	VA7	VA6	VA5	VA4	VA3	VA2	VA1	VA0

Table 22. Character fonts, $9 \leq$ number of lines ≤ 16 ($M2 = 1, M1 = 0$)

SAG	A15	A14	A13	A12	A11	A10	A9	A8	A7	A6	A5	A4	A3	A2	A1	A0
Character code	0	0	0	0	D7	D6	D5	D4	D3	D2	D1	D0	0	0	0	0
+ROW select address	0	0	0	0	0	0	0	0	0	0	0	0	R3	R2	R1	R0
CG RAM address	VA15	VA14	VA13	VA12	VA11	VA10	VA9	VA8	VA7	VA6	VA5	VA4	VA3	VA2	VA1	VA0

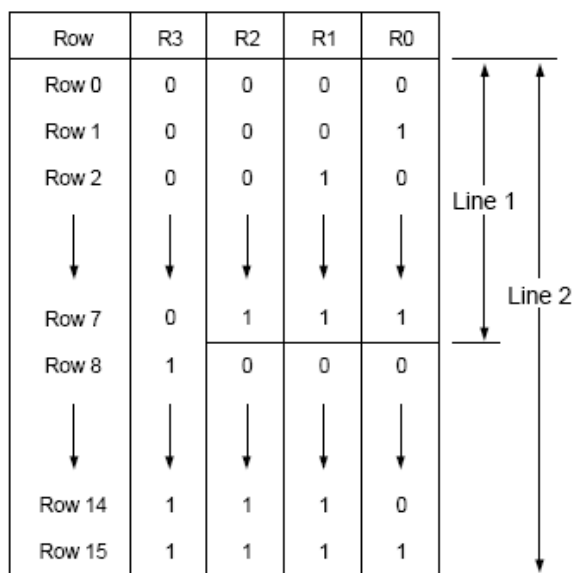

Figure 45. Row select address

Note: Lines = 1: lines in the character bitmap ≤ 8
 Lines = 2: lines in the character bitmap ≥ 9

10.3.1. $M1 = 1$

The SED1335 series automatically converts all bits set in bit 6 of character code for CG RAM 2 to zero. Because of this, the CG RAM data areas become contiguous in display memory.

When writing data to CG RAM:

- Calculate the address as for $M1 = 0$.
- Change bit 6 of the character code from “1” to “0”.

10.3.2. CG RAM addressing example

- Define a pattern for the “A” in Figure 26.
- The CG RAM table start address is 4800H.
- The character code for the defined pattern is 80H (the first character code in the CG RAM area).

As the character code table in Figure 46 shows, codes 80H to 9FH and E0H to FFH are allocated to the CG RAM

and can be used as desired. 80H is thus the first code for CG RAM. As characters cannot be used if only using graphics mode, there is no need to set the CG RAM data.

Table 23. Character data example

CGRAM AD	5CH	Reverse the CG RAM address calculation to calculate SAG
P1	00H	
P2	40H	
CSRDIR	4CH	Set cursor shift direction to right
CSRW	46H	CG RAM start address is 4800H
P1	00H	
P2	48H	
MWRITE	42H	
P	70H	Write ROW 0 data
P2	88H	Write ROW 1 data
P3	88H	Write ROW 2 data
P4	88H	Write ROW 3 data
P5	F8H	Write ROW 4 data
P6	88H	Write ROW 5 data
P7	88H	Write ROW 6 data
P8	00H	Write ROW 7 data
P8	00H	Write ROW 8 data
↓	↓	↓
P16	00H	Write ROW 15 data

10.4. Character Codes

The following figure shows the character codes and the codes allocated to CG RAM. All codes can be used by the CG RAM if not using the internal ROM.

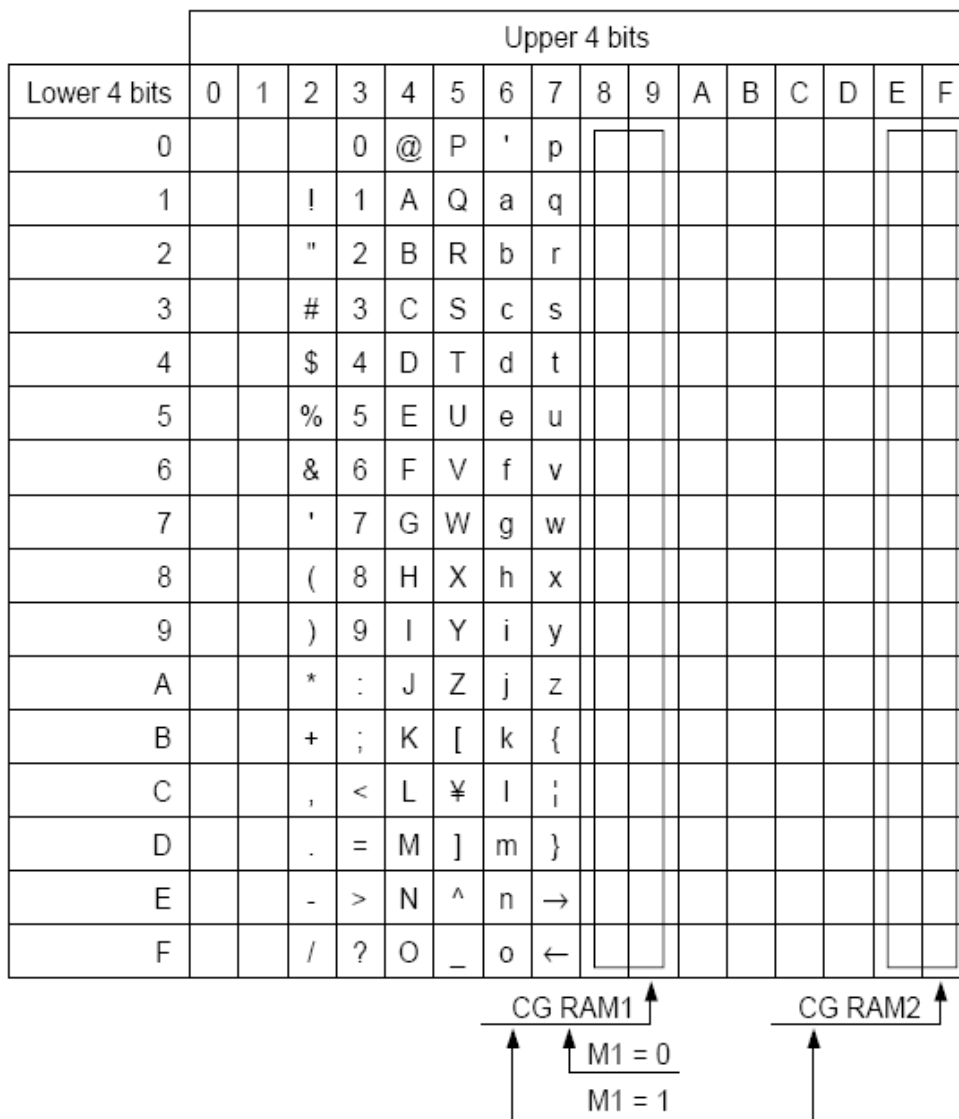

Figure 46. On-chip character codes

10.4 Internal Character Generator Font

		Character code bits 0 to 3															
		0	1	2	3	4	5	6	7	8	9	A	B	C	D	E	F
Character code bits 4 to 7	2	!	"	#	\$	%	&	'	()	*	+	,	-	.	/	
	3	0	1	2	3	4	5	6	7	8	9	:	;	<	=	>	
	4	@	A	B	C	D	E	F	G	H	I	J	K	L	M	N	
	5	P	Q	R	S	T	U	V	W	X	Y	Z	[]	^	_	
	6	`	a	b	c	d	e	f	g	h	i	j	k	l	m	n	
	7	o	p	q	r	s	t	u	v	w	x	y	z	{	}	~	
	A		¡	¢	£	¤	¥	¦	§	¨	©	ª	«	¬	®	¯	
	B	°	±	²	³	´	µ	¶	·	¸	¹	º	»	¼	½	¾	
	C	¿	À	Á	Â	Ã	Ä	Å	Æ	Ç	È	É	Ê	Ë	Ì	Í	
	D	Î	Ï	Ð	Ñ	Ò	Ó	Ô	Õ	Ö	×	Ø	Ù	Ú	Û	Ü	
1																	

11. INTERFACE PIN CONNECTIONS

CN1

PIN	SYMBOL	I/O	FUNCTION																																								
1	DB7	I/O	Tristate input/output pins. Connect these pins to an 8- or 16-bit microprocessor bus.																																								
2	DB6	I/O	Tristate input/output pins. Connect these pins to an 8- or 16-bit microprocessor bus.																																								
3	DB5	I/O	Tristate input/output pins. Connect these pins to an 8- or 16-bit microprocessor bus.																																								
4	DB4	I/O	Tristate input/output pins. Connect these pins to an 8- or 16-bit microprocessor bus.																																								
5	DB3	I/O	Tristate input/output pins. Connect these pins to an 8- or 16-bit microprocessor bus.																																								
6	DB2	I/O	Tristate input/output pins. Connect these pins to an 8- or 16-bit microprocessor bus.																																								
7	DB1	I/O	Tristate input/output pins. Connect these pins to an 8- or 16-bit microprocessor bus.																																								
8	DB0	I/O	Tristate input/output pins. Connect these pins to an 8- or 16-bit microprocessor bus.																																								
9	/WR or R/W	I	<p>When the 8080 family interface is selected, this signal acts as the active-LOW write strobe. The bus data is latched on the rising edge of this signal.</p> <p>When the 6800 family interface is selected, this signal acts as the read/write control signal. Data is read from the SED1335 series if this signal is HIGH, and written to the SED1335 series if it is LOW.</p>																																								
10	/RD or E	I	<p>When the 8080 family interface is selected, this signal acts as the active-LOW read strobe. The SED1335 series output buffers are enabled when this signal is active.</p> <p>When the 6800 family interface is selected, this signal acts as the active-HIGH enable clock. Data is read from or written to the SED1335 series when this clock goes HIGH.</p>																																								
11	A0	I	<p>8080 family interface</p> <table border="1"> <thead> <tr> <th>A0</th> <th>\overline{RD}</th> <th>\overline{WR}</th> <th>Function</th> </tr> </thead> <tbody> <tr> <td>0</td> <td>0</td> <td>1</td> <td>Status flag read</td> </tr> <tr> <td>1</td> <td>0</td> <td>1</td> <td>Display data and cursor address read</td> </tr> <tr> <td>0</td> <td>1</td> <td>0</td> <td>Display data and parameter write</td> </tr> <tr> <td>1</td> <td>1</td> <td>0</td> <td>Command write</td> </tr> </tbody> </table> <p>6800 family interface</p> <table border="1"> <thead> <tr> <th>A0</th> <th>R/\overline{W}</th> <th>E</th> <th>Function</th> </tr> </thead> <tbody> <tr> <td>0</td> <td>1</td> <td>1</td> <td>Status flag read</td> </tr> <tr> <td>1</td> <td>1</td> <td>1</td> <td>Display data and cursor address read</td> </tr> <tr> <td>0</td> <td>0</td> <td>1</td> <td>Display data and parameter write</td> </tr> <tr> <td>1</td> <td>0</td> <td>1</td> <td>Command write</td> </tr> </tbody> </table>	A0	\overline{RD}	\overline{WR}	Function	0	0	1	Status flag read	1	0	1	Display data and cursor address read	0	1	0	Display data and parameter write	1	1	0	Command write	A0	R/ \overline{W}	E	Function	0	1	1	Status flag read	1	1	1	Display data and cursor address read	0	0	1	Display data and parameter write	1	0	1	Command write
A0	\overline{RD}	\overline{WR}	Function																																								
0	0	1	Status flag read																																								
1	0	1	Display data and cursor address read																																								
0	1	0	Display data and parameter write																																								
1	1	0	Command write																																								
A0	R/ \overline{W}	E	Function																																								
0	1	1	Status flag read																																								
1	1	1	Display data and cursor address read																																								
0	0	1	Display data and parameter write																																								
1	0	1	Command write																																								
12	/RST	I	This active-LOW input performs a hardware reset on the SED1335 series. It is a Schmitt-trigger input for enhanced noise immunity; however, care should be taken to ensure that it is not triggered if the supply voltage is lowered.																																								
13	/CS	I	<p>Chip select.</p> <p>This active-LOW input enables the SED1335 series. It is usually connected to the output of an address decoder device that maps the SED1335 series into the memory space of the controlling microprocessor.</p>																																								

14	LEDA	I	LED anode (+5V)
15	NC	-	No connect
16	VSS	I	Ground pin, connected to 0V
17	VDD	I	Power supply pin for logic .(+5V)
18	NC	-	No connect

12.RELIABILITY

Content of Reliability Test

Environmental Test				
No.	Test Item	Content of Test	Test Condition	Applicable Standard
1	High temperature storage	Endurance test applying the high storage temperature for a long time.	80 °C 200 hrs	
2	Low temperature storage	Endurance test applying the low storage temperature for a long time.	-30 °C 200 hrs	
3	High temperature operation	Endurance test applying the electric stress (Voltage & Current) and the thermal stress to the element for a long time.	70 °C 200 hrs	
4	Low temperature operation	Endurance test applying the electric stress under low temperature for a long time.	-20 °C 200 hrs	
5	High temperature Humidity storage	Endurance test applying the high temperature and high humidity storage for a long time.	50 °C , 90 RH 96 hrs	MIL-202E-103B JIS-C5023
6	High temperature Humidity operation	Endurance test applying the electric stress (Voltage & Current) and temperature humidity stress to the element for a long time.	50 °C , 90 RH 96 hrs	MIL-202E-103B JIS-C5023
7	Temperature cycle	Endurance test applying the low and high temperature cycle. $ \begin{array}{c} -20^{\circ}\text{C} \quad \rightleftharpoons \quad 25^{\circ}\text{C} \quad \rightleftharpoons \quad 70^{\circ}\text{C} \\ 30\text{min.} \quad \leftarrow \quad 5\text{min.} \quad \leftarrow \quad 30\text{min.} \\ \longleftarrow \hspace{10em} \longrightarrow \\ \text{1 cycle} \end{array} $	-20°C - 70°C 10 cycles	
Mechanical Test				
8	Vibration test	Endurance test applying the vibration during transportation and using.	10-22Hz → 1.5mmp-p 22-500Hz → 1.5G Total 0.5hrs	MIL-202E-201A JIS-C5025 JIS-C7022-A-10
9	Shock test	Constructional and mechanical endurance test applying the shock during transportation.	50G half sign wave 1l msdc 3 times of each direction	MIL-202E-213B

10	Atmospheric pressure test	Endurance test applying the atmospheric pressure during transportation by air.	115 mbar 40 hrs	MIL-202E-105C
Others				
11	Static electricity test	Endurance test applying the electric stress to the terminal.	VS=800V, RS=1.5 k CS=100 pF 1 time	MIL-883B-3015.1

*** Supply voltage for logic system = 3V. Supply voltage for LCD system = Operating voltage at 25°C.

Failure Judgement Criterion

Criterion Item	Test Item No.											Failure Judgment Criterion	
	1	2	3	4	5	6	7	8	9	10	11		
Basic specification													Out of the Basic Specification
Electrical characteristic													Out of the DC and AC Characterstic
Mechanical characterstic													Out of the Mechanical Specification Color change : Out of Limit Apperance Specification
Optical characterstic													Out of the Apperance Standard

13. QUALITY GUARANTEE

Acceptable Quality Level

Each lot should satisfy the quality level defined as follows.

- Inspection method : MIL-STD-105E LEVEL II Normal one time sampling
- AQL

Partition	AQL	Definition
A: Major	0.4%	Functional defective as product
B: Minor	1.5%	Satisfy all functions as product but not satisfy cosmetic standard

Definition of 'LOT'

One lot means the delivery quantity to customer at one time.

Conditions of Cosmetic Inspection

Environmental condition

The inspection should be performed at the 1cm of height from the LCD module under 2 pieces of 40W white fluorescent lamps (Normal temperature 20~25°C and normal humidity 60±15%RH).

Inspection method

The visual check should be performed vertically at more than 30cm distance from the LCD panel.

Driving voltage

The VO value which the most optimal contrast can be obtained near the specified VO in the specification. (Within $\pm 0.5V$ of typical value at 25°C.).

14. INSPECTION CRITERIA
14.1 Module Cosmetic Criteria

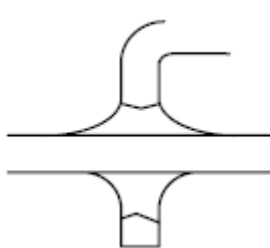
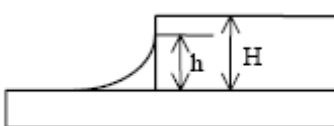
No.	Item	Judgement Criterion	Partition
1	Difference in Spec.	None allowed	Major
2	Pattern peeling	No substrate pattern peeling and floating	Major
3	Soldering defects	No soldering missing No soldering bridge No cold soldering	Major Major Major
4	Resist flaw on substrate	Invisible copper foil ('0.5mm or more) on substrate pattern	Minor
5	Accretion of metallic Foreign matter	No soldering dust No accretion of metallic foreign matters (Not exceed '0.2mm)	Minor Minor
6	Stain	No stain to spoil cosmetic badly	Minor
7	Plate discoloring	No plate fading, rusting and discoloring	Minor
8	Solder amount	a. Soldering side of PCB Solder to form a 'Filet' all around the lead. Solder should not hide the lead form perfectly. (too much) b. Components side (In case of 'Through Hole PCB') Solder to reach the Components side of PCB.	Minor
	1. Lead parts		
	2. Flat packages	Either 'Toe' (A) or 'Seal' (B) of the lead to be covered by 'Filet'. Lead form to be assume over solder. A B	Minor
	3. Chips	$(3/2) H \geq h \geq (1/2) H$ 	Minor

14.2 Screen Cosmetic Criteria (Non-Operating)

No.	Defect	Judgement Criterion	Partition										
1	Spots	In accordance with <i>Screen Cosmetic Criteria (Operating) No.1.</i>	Minor										
2	Lines	In accordance with <i>Screen Cosmetic Criteria (Operating) No.2.</i>	Minor										
3	Bubbles in polarizer	<table border="1"> <thead> <tr> <th>Size : d mm</th> <th>Acceptable Qty in active area</th> </tr> </thead> <tbody> <tr> <td>d ≤ 0.3</td> <td>Disregard</td> </tr> <tr> <td>0.3 < d ≤ 1.0</td> <td>3</td> </tr> <tr> <td>1.0 < d ≤ 1.5</td> <td>1</td> </tr> <tr> <td>1.5 < d</td> <td>0</td> </tr> </tbody> </table>	Size : d mm	Acceptable Qty in active area	d ≤ 0.3	Disregard	0.3 < d ≤ 1.0	3	1.0 < d ≤ 1.5	1	1.5 < d	0	Minor
Size : d mm	Acceptable Qty in active area												
d ≤ 0.3	Disregard												
0.3 < d ≤ 1.0	3												
1.0 < d ≤ 1.5	1												
1.5 < d	0												
4	Scratch	In accordance with spots and lines operating cosmetic criteria. When the light reflects on the panel surface, the scratches are not to be remarkable.	Minor										
5	Allowable density	Above defects should be separated more than 30mm each other.	Minor										
6	Coloration	Not to be noticeable coloration in the viewing area of the LCD panels. Back-lit type should be judged with back-lit on state only.	Minor										
7	Contamination	Not to be noticeable.	Minor										

14.3. Screen Cosmetic Criteria (Operating)

No.	Defect	Judgement Criterion	Partition																				
1	Spots	<p>A) Clear Note :</p> <table border="1"> <thead> <tr> <th>Size : d mm</th> <th>Acceptable Qty in active area</th> </tr> </thead> <tbody> <tr> <td>d ≤ 0.1</td> <td>Disregard</td> </tr> <tr> <td>0.1 < d ≤ 0.2</td> <td>3</td> </tr> <tr> <td>0.2 < d ≤ 0.3</td> <td>2</td> </tr> <tr> <td>0.3 < d</td> <td>0</td> </tr> </tbody> </table> <p>Including pin holes and defective dots which must be within one pixel size.</p> <p>B) Unclear Size :</p> <table border="1"> <thead> <tr> <th>Size : d mm</th> <th>Acceptable Qty in active area</th> </tr> </thead> <tbody> <tr> <td>d ≤ 0.2</td> <td>Disregard</td> </tr> <tr> <td>0.2 < d ≤ 0.5</td> <td>6</td> </tr> <tr> <td>0.5 < d ≤ 0.7</td> <td>2</td> </tr> <tr> <td>0.7 < d</td> <td>0</td> </tr> </tbody> </table>	Size : d mm	Acceptable Qty in active area	d ≤ 0.1	Disregard	0.1 < d ≤ 0.2	3	0.2 < d ≤ 0.3	2	0.3 < d	0	Size : d mm	Acceptable Qty in active area	d ≤ 0.2	Disregard	0.2 < d ≤ 0.5	6	0.5 < d ≤ 0.7	2	0.7 < d	0	Minor
Size : d mm	Acceptable Qty in active area																						
d ≤ 0.1	Disregard																						
0.1 < d ≤ 0.2	3																						
0.2 < d ≤ 0.3	2																						
0.3 < d	0																						
Size : d mm	Acceptable Qty in active area																						
d ≤ 0.2	Disregard																						
0.2 < d ≤ 0.5	6																						
0.5 < d ≤ 0.7	2																						
0.7 < d	0																						

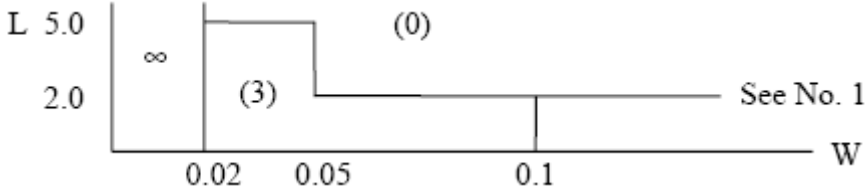
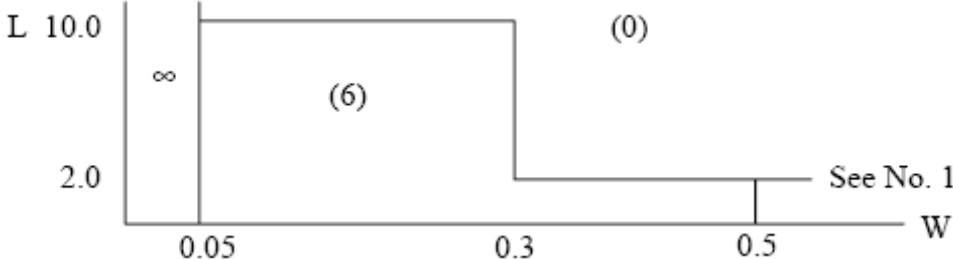
2	Lines	<p>A)Clear</p>  <p>Note : () - Acceptable Qty in active area L -Length (mm) W - Width (mm) ∞ - Disregard</p> <p>B) Unclear</p> 	Minor
---	-------	--	-------

‘Clear’ = The shade and size are not changed by VO.

‘Unclear’ = The shade and size are changed by VO.

14.4. Screen Cosmetic Criteria (Operating) (Continued)

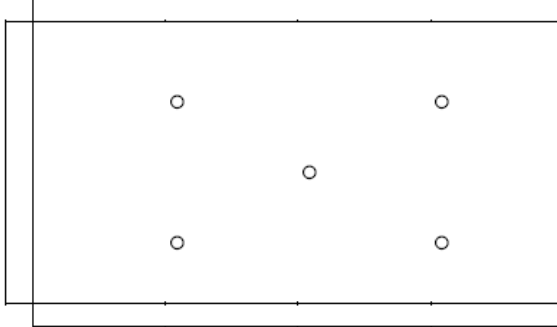
No.	Defect	Judgement Criterion	Partition
3	Rubbing line	Not to be noticeable.	
4	Allowable density	Above defects should be separated more than 10mm each other.	Minor
5	Rainbow	Not to be noticeable.	Minor
6	Dot size	To be 95% ~ 105% of the dot size (Typ.) in drawing. Partial defects of each dot (ex. pin-hole) should be treated as ‘Spot’. (see <i>Screen Cosmetic Criteria (Operating) No.1</i>)	Minor
7	Uneven brightness (only back-lit type module)	<p>Uneven brightness must be $B_{MAX} / B_{MIN} \leq 2$</p> <ul style="list-style-type: none"> - BMAX : Max. value by measure in 5 points - BMIN : Min. value by measure in 5 points <p>Divide active area into 4 vertically and horizontally. Measure 5 points shown in the following figure.</p>  <p>○ : Measuring points</p>	Minor

Note :

- (1) Size : $d = (\text{long length} + \text{short length}) / 2$
- (2) The limit samples for each item have priority.

(3) Complexed defects are defined item by item, but if the number of defects are defined in above table, the total number should not exceed 10.

- (4) In case of 'concentration', even the spots or the lines of 'disregarded' size should not allowed.

Following three situations should be treated as 'concentration'.

- 7 or over defects in circle of '5mm.
- 10 or over defects in circle of '10mm.
- 20 or over defects in circle of '20mm.

15. PRECAUTIONS FOR USING LCD MODULES

Handing Precautions

- (1) The display panel is made of glass. Do not subject it to a mechanical shock by dropping it or impact.
- (2) If the display panel is damaged and the liquid crystal substance leaks out, be sure not to get any in your mouth. If the substance contacts your skin or clothes, wash it off using soap and water.
- (3) Do not apply excessive force to the display surface or the adjoining areas since this may cause the color tone to vary.
- (4) The polarizer covering the display surface of the LCD module is soft and easily scratched. Handle this polarizer carefully.
- (5) If the display surface becomes contaminated, breathe on the surface and gently wipe it with a soft dry cloth. If it is heavily contaminated, moisten cloth with one of the following solvents :
 - Isopropyl alcohol
 - Ethyl alcohol
- (6) Solvents other than those above-mentioned may damage the polarizer. Especially, do not use the following.
 - Water
 - Ketone
 - Aromatic solvents
- (7) Exercise care to minimize corrosion of the electrode. Corrosion of the electrodes is accelerated by water droplets, moisture condensation or a current flow in a high-humidity environment.
- (8) Install the LCD Module by using the mounting holes. When mounting the LCD module make sure it is free of twisting, warping and distortion. In particular, do not forcibly pull or bend the I/O cable or the backlight cable.
- (9) Do not attempt to disassemble or process the LCD module.
- (10) NC terminal should be open. Do not connect anything.
- (11) If the logic circuit power is off, do not apply the input signals.
- (12) To prevent destruction of the elements by static electricity, be careful to maintain an optimum work environment.
 - Be sure to ground the body when handling the LCD modules.

- Tools required for assembling, such as soldering irons, must be properly grounded.
- To reduce the amount of static electricity generated, do not conduct assembling and other work under dry conditions.
 - The LCD module is coated with a film to protect the display surface. Exercise care when peeling off this protective film since static electricity may be generated.

Storage Precautions

When storing the LCD modules, avoid exposure to direct sunlight or to the light of fluorescent lamps. Keep the modules in bags (avoid high temperature high humidity and low temperatures below 0 °C). Whenever possible, the LCD modules should be stored in the same conditions in which they were shipped from our company.

Others

Liquid crystals solidify under low temperature (below the storage temperature range) leading to defective orientation or the generation of air bubbles (black or white). Air bubbles may also be generated if the module is subject to a low temperature.

If the LCD modules have been operating for a long time showing the same display patterns, the display patterns may remain on the screen as ghost images and a slight contrast irregularity may also appear. A normal operating status can be regained by suspending use for some time. It should be noted that this phenomenon does not adversely affect performance reliability.

To minimize the performance degradation of the LCD modules resulting from destruction caused by static electricity etc., exercise care to avoid holding the following sections when handling the modules.

- Exposed area of the printed circuit board.
- Terminal electrode sections.

16. USING LCD MODULES

Liquid Crystal Display Modules

LCD is composed of glass and polarizer. Pay attention to the following items when handling.

- (1) Please keep the temperature within specified range for use and storage. Polarization degradation, bubble generation or polarizer peel-off may occur with high temperature and high humidity.
- (2) Do not touch, push or rub the exposed polarizers with anything harder than an HB pencil lead (glass, tweezers, etc.).
- (3) N-hexane is recommended for cleaning the adhesives used to attach front/rear polarizers and reflectors made of organic substances which will be damaged by chemicals such as acetone, toluene, ethanol and isopropylalcohol.
- (4) When the display surface becomes dusty, wipe gently with absorbent cotton or other soft material like chamois soaked in petroleum benzine. Do not scrub hard to avoid damaging the display surface.
- (5) Wipe off saliva or water drops immediately, contact with water over a long period of time may cause deformation or color fading.
- (6) Avoid contacting oil and fats.
- (7) Condensation on the surface and contact with terminals due to cold will damage, stain or dirty the polarizers. After products are tested at low temperature they must be warmed up in a container before coming in contact with room temperature air.

- (8) Do not put or attach anything on the display area to avoid leaving marks on.
- (9) Do not touch the display with bare hands. This will stain the display area and degradate insulation between terminals (some cosmetics are determinated to the polarizers).
- (10) As glass is fragile. It tends to become or chipped during handling especially on the edges. Please avoid dropping or jarring.

Installing LCD Modules

The hole in the printed circuit board is used to fix LCM as shown in the picture below. Attend to the following items when installing the LCM.

- (1) Cover the surface with a transparent protective plate to protect the polarizer and LC cell.

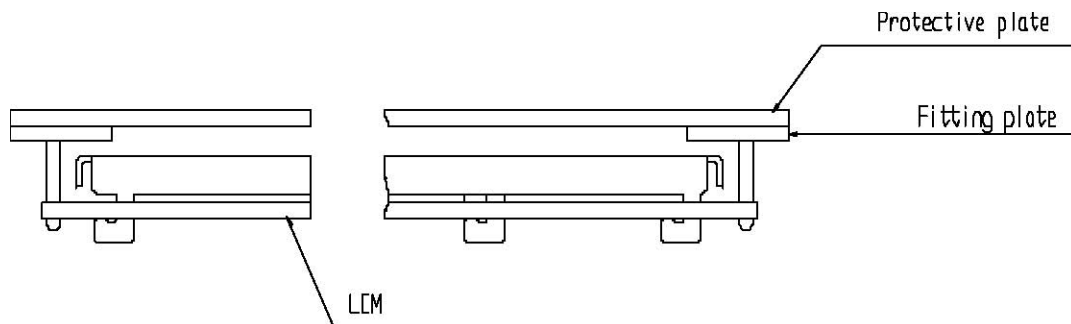

- (2) When assembling the LCM into other equipment, the spacer to the bit between the LCM and the fitting plate should have enough height to avoid causing stress to the module surface, refer to the individual specifications for measurements. The measurement tolerance should be 0.1mm.

Precaution for Handling LCD Modules

Since LCM has been assembled and adjusted with a high degree of precision, avoid applying excessive shocks to the module or making any alterations or modifications to it.

- (1) Do not alter, modify or change the the shape of the tab on the metal frame.
- (2) Do not make extra holes on the printed circuit board, modify its shape or change the positions of components to be attached.
- (3) Do not damage or modify the pattern writing on the printed circuit board.
- (4) Absolutely do not modify the zebra rubber strip (conductive rubber) or heat seal connector.
- (5) Except for soldering the interface, do not make any alterations or modifications with a soldering iron.
- (6) Do not drop, bend or twist LCM.

Electro-Static Discharge Control

Since this module uses a CMOS LSI, the same careful attention should be paid to electrostatic discharge as for an ordinary CMOS IC.

- (1) Make certain that you are grounded when handing LCM.
- (2) Before remove LCM from its packing case or incorporating it into a set, be sure the module and your body have the same electric potential.
- (3) When soldering the terminal of LCM, make certain the AC power source for the soldering iron does not leak.
- (4) When using an electric screwdriver to attach LCM, the screwdriver should be of ground potentiality to

minimize as much as possible any transmission of electromagnetic waves produced sparks coming from the commutator of the motor.

(5) As far as possible make the electric potential of your work clothes and that of the work bench the ground potential.

(6) To reduce the generation of static electricity be careful that the air in the work is not too dried. A relative humidity of 50%~60% is recommended.

Precaution for soldering to the LCM

(1) Observe the following when soldering lead wire, connector cable and etc. to the LCM.

- Soldering iron temperature : 280 C ± 10 C.
- Soldering time : 3-4 sec.
- Solder : eutectic solder.

If soldering flux is used, be sure to remove any remaining flux after finishing to soldering operation. (This does not apply in the case of a non-halogen type of flux.) It is recommended that you protect the LCD surface with a cover during soldering to prevent any damage due to flux spatters.

(2) When soldering the electroluminescent panel and PC board, the panel and board should not be detached more than three times. This maximum number is determined by the temperature and time conditions mentioned above, though there may be some variance depending on the temperature of the soldering iron.

(3) When remove the electroluminescent panel from the PC board, be sure the solder has completely melted, the soldered pad on the PC board could be damaged.

Precautions for Operation

(1) Viewing angle varies with the change of liquid crystal driving voltage (VO). Adjust VO to show the best contrast.

(2) Driving the LCD in the voltage above the limit shortens its life.

(3) Response time is greatly delayed at temperature below the operating temperature range. However, this does not mean the LCD will be out of the order. It will recover when it returns to the specified temperature range.

(4) If the display area is pushed hard during operation, the display will become abnormal. However, it will return to normal if it is turned off and then back on.

(5) Condensation on terminals can cause an electrochemical reaction disrupting the terminal circuit. Therefore, it must be used under the relative condition of 40 °C , 50% RH.

(6) When turning the power on, input each signal after the positive/negative voltage becomes stable.

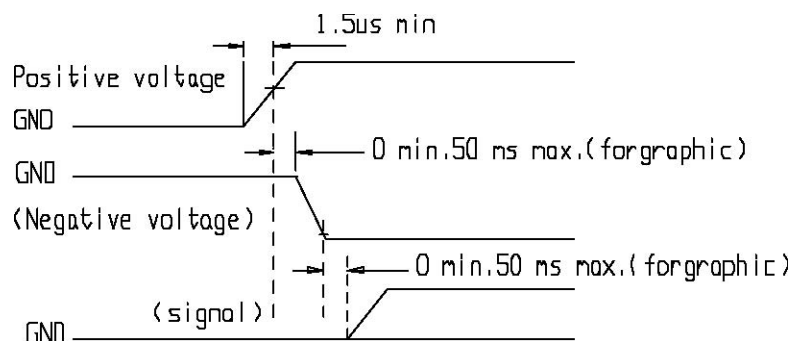

Storage

When storing LCDs as spares for some years, the following precaution are necessary.

(1) Store them in a sealed polyethylene bag. If properly sealed, there is no need for dessicant.

(2) Store them in a dark place. Do not expose to sunlight or fluorescent light, keep the temperature between 0 C and 35 C.

(3) The polarizer surface should not come in contact with any other objects. (We advise you to store them in the container in which they were shipped.)

Safety

(1) It is recommended to crush damaged or unnecessary LCDs into pieces and wash them off with solvents such as acetone and ethanol, which should later be burned.

(2) If any liquid leaks out of a damaged glass cell and comes in contact with the hands, wash off thoroughly with soap and water.

Limited Warranty

Unless agreed between YAOYU and customer, YAOYU will replace or repair any of its LCD modules which are found to be functionally defective when inspected in accordance with YAOYU LCD acceptance standards (copies available upon request) for a period of one year from date of shipments. Cosmetic/visual defects must be returned to YAOYU within 90 days of shipment. Confirmation of such date shall be based on freight documents. The warranty liability of YAOYU limited to repair and/or replacement on the terms set forth above. YAOYU will not be responsible for any subsequent or consequential events.

Return LCM under warranty

No warranty can be granted if the precautions stated above have been disregarded. The typical examples of violations are :

- Broken LCD glass.
- PCB eyelet's damaged or modified.
- PCB conductors damaged.
- Circuit modified in any way, including addition of components.
- PCB tampered with by grinding, engraving or painting varnish.
- soldering to or modifying the bezel in any manner.

Module repairs will be invoiced to the customer upon mutual agreement. Modules must be returned with sufficient description of the failures or defects. Any connectors or cable installed by the customer must be removed completely without damaging the PCB eyelet's, conductors and terminals.