

# SPECIFICATION



## YMSP-G240128K-2DBSWSD

December 13, 2007  
Version 1.0





## CONTENTS

1.	GERENAL SPECIIFICATIIONS- .....	4
2.	FEATURES .....	4
3.	MACHANICAL SPECIFICATION-.....	5
4.	ABSOLUTE MAXIMUM RATING .....	5
5.	ELECTRICAL CHARACTERISTICS .....	5
6.	OPTICAL CHARACTERISTICS-.....	6
7.	ELECTRICAL CHARACTERISTICS AND TIMING CHARACTERISTICS-.....	7
8.	PIN ASSIGNMENT-.....	10
9.	BLOCK DIAGRAM- .....	11
10.	OUTPUT DIMENSIONS .....	12
11.	ENVIRONMENTAL ABSOLUTE MAXIMUM RATINGS ---	113
12.	RELIABILITY .....	13
13.	PRECAUTION FOR USE-.....	14



## 1. GENERAL SPECIFICATIONS:

### 1-1 SCOPE:

This specification covers the delivery requirements for the liquid crystal display delivered by YAoyu TECHNOLOGY to Customer.

### 1-2 PRODUCTS:

Liquid Crystal Display Module (LCM)

### 1-3 MODULE NAME:

**YMSP-G240128K-2DBSWSD**

## 2. FEATURES:

Item	Standard Value
Display Type	240*128 dots
LCD Type	<input type="checkbox"/> FSTN, BLUE, Transmissive, Negative, Extended TEMP <input type="checkbox"/> FSTN, Transflective, Positive, Extended TEMP <input checked="" type="checkbox"/> STN, BLUE, Transmissive, Negative, Extended TEMP <input type="checkbox"/> STN, GREY, Transflective, Positive, Extended TEMP <input type="checkbox"/> STN, Yellow-GREEN, Positive, Extended TEMP
Driver Condition	LCD Module: 1/128 Duty, 1/12 Bias
Viewing Direction	6 O'clock
Backlight Type	<input type="checkbox"/> YELLOW-GREEN LED BL <input checked="" type="checkbox"/> WHITE EDGE LED BL <input type="checkbox"/> CCFL WHITE BL
Weight	TBD
Interface	8-bit 6800/8080 MPU interface
Driver IC	T6963C

### 3. MACHANICAL SPECIFICATIONS

ITEM	SPECIFICATIONS	UNIT
OUTLINE DIMENSIONS	120.0(L) X73.0(W) X 12.5MAX(H)	mm
VIEWING AREA	93.0(L)X48.0(W)	mm
ACTIVE AREA	78.77(L)X42.21(W)	mm
DISP.CONSTRUCTION	240*128 dots	--
DOT SIZE	0.30(L)X0.30(W)	mm
DOT PITCH	0.33(L)X0.33(W)	mm
ASSY.TYPE	COB	--
WEIGHT	TBD	g

Note : For detailed information please refer to LCM drawing

### 4. ABSOLUTE MAXIMUM RATING

ITEM	SYMBOL	CONDITION	STANDARD VALUE			UNIT
			MIN	TYP	MAX	
POWER SUPPLY FOR LOGIC	VDD	Ta=25°C	-0.3	--	6.5	V
INPUT VOLTAGE	VIN	Ta=25°C	-0.3	--	VDD+0.3	V
OPERATION TEMPERATURE	TOPR	---	-20	--	+70	°C
STORAGE TEMPERATURE	TSTG	---	-30	--	+80	°C
Storage Humidity	H <sub>b</sub>	Ta < 40 °C	-	--	90	%RH

NOTES:

- (1) LCM should be grounded during handling LCM.

### 5. ELECTRICAL CHARACTERISTICS

ITEM	SYMBOL	CONDITION	STANDARD VALUE			UNIT
			MIN	TYP	MAX	
POWER SUPPLY VOLTAGE	VDD — VSS	Ta= +25°C	4.8	5.0	5.2	V
POWER SUPPLY FOR LCD DRIVING	V <sub>lcd</sub>	Ta= +25°C	--	TBD	--	V
INPUT VOLTAGE "H" LEVEL	V <sub>IH</sub>	--	0.8VDD	--	VDD	V
INPUT VOLTAGE "L" LEVEL	V <sub>IL</sub>	--	VSS	--	0.2VDD	V
OUTPUT VOLTAGE "H" LEVEL	V <sub>OH</sub>	I <sub>OH</sub> =-0.5mA	0.8VDD	--	VDD	V
OUTPUT VOLTAGE "L" LEVEL	V <sub>OL</sub>	I <sub>OL</sub> =-0.5mA	VSS	--	0.2VDD	V
Supply Current	I <sub>DD</sub>	VDD = 5.0 V	--	3	5	mA
LCM Driver Voltage	V <sub>op</sub>	VDD-V0 (-20°C)	-	-	-	V
		VDD-V0 (25°C)	-	15.0	-	V
		VDD-V0 (70°C)	-	-	-	V

## 6. OPTICAL CHARACTERISTICS

### (1) DEFINITION OF VIEWING ANGLE

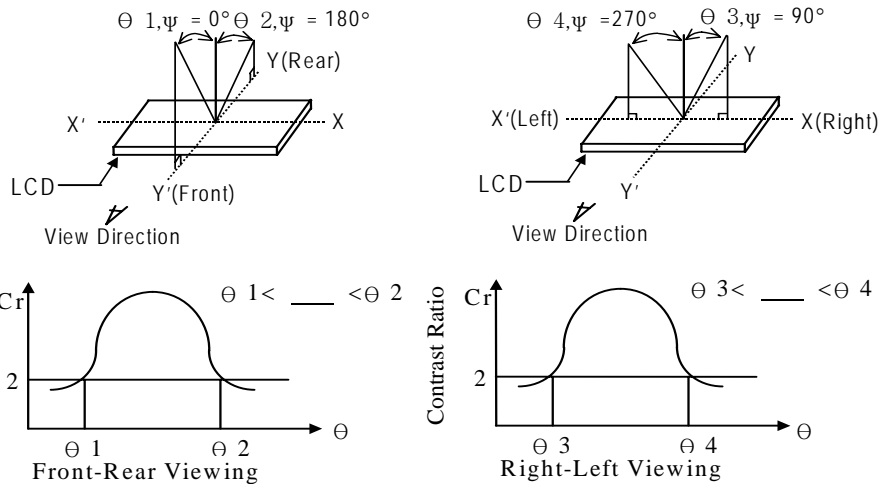

### (2) DEFINITION OF CONTRAST

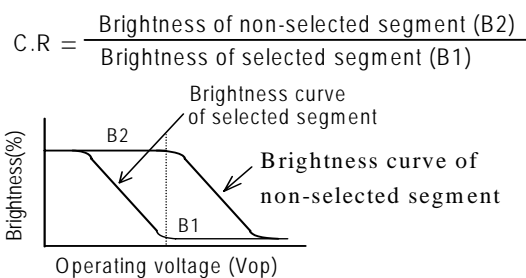

### (3) DEFINITION OF RESPONSE

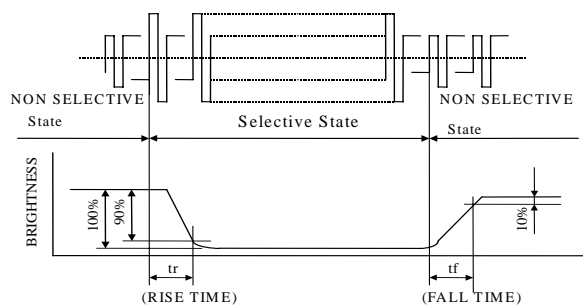

### (4) Measuring Instruments For Electro-optical Characteristics

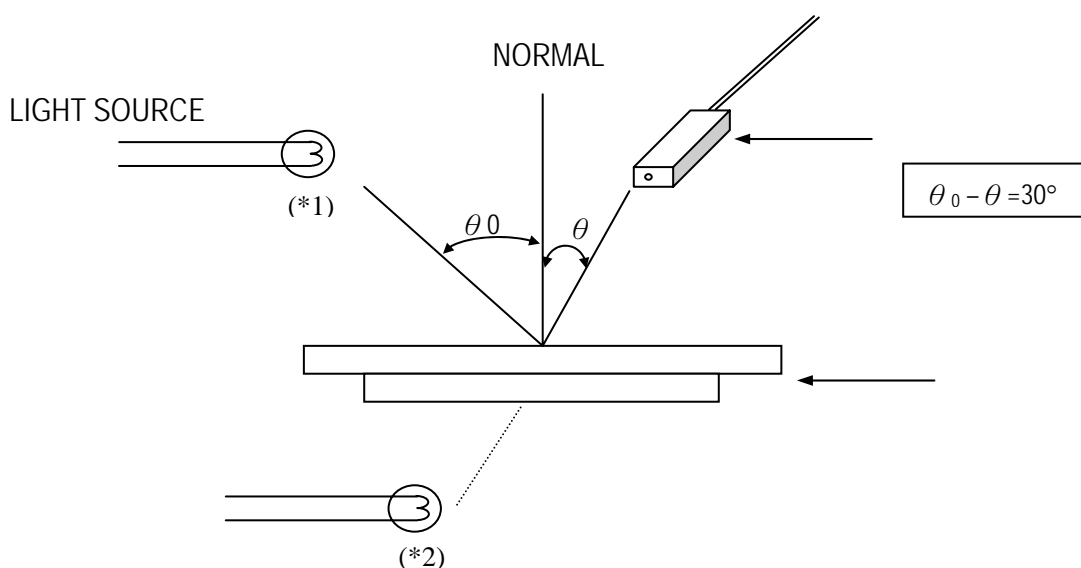

## 7.ELECTRICAL CHARACTERISTICS AND TIMING

### CHARACTERISTICS

#### 7.1 DC Characteristics

TEST CONDITIONS (Unless otherwise noted,  $V_{SS} = 0V$ ,  $V_{DD} = 5.0V \pm 10\%$ ,  $T_a = -20$  to  $75^\circ C$ )

ITEM	SYMBOL	TEST CIRCUIT	TEST CONDITIONS	MIN	TYP.	MAX	UNIT	PIN NAME
Operating Voltage	$V_{DD}$	—	—	4.5	5.0	5.5	V	$V_{DD}$
Input	H Level	$V_{IH}$	—	$V_{DD} - 2.2$	—	$V_{DD}$	V	Input pins
	L Level	$V_{IL}$	—	0	—	0.8	V	Input pins
Output Voltage	H Level	$V_{OH}$	—	$V_{DD} - 0.3$	—	$V_{DD}$	V	Output pins
	L Level	$V_{OL}$	—	0	—	0.3	V	Output pins
Output Resistance	H Level	$R_{OH}$	$V_{OUT} = V_{DD} - 0.5V$	—	—	400	$\Omega$	Output pins
	L Level	$R_{OL}$	$V_{OUT} = 0.5V$	—	—	400	$\Omega$	Output pins
Input Pull-up Resistance	RPU	—	—	50	100	200	$k\Omega$	(Note 1)
Operating Frequency	$f_{OSC}$	—	—	0.4	—	5.5	MHz	
Current Consumption (Operating)	$I_{DD} (1)$	—	$V_{DD} = 5.0V$ (Note 2) $f_{OSC} = 3.0MHz$	—	3.3	6	mA	$V_{DD}$
Current Consumption (Halt)	$I_{DD} (2)$	—	$V_{DD} = 5.0V$	—	—	3	$\mu A$	$V_{DD}$

(Note 1) Applied  $\overline{T1}$ ,  $\overline{T2}$ ,  $\overline{RESET}$

(Note 2)  $MDS = L$ ,  $MD0 = L$ ,  $MD1 = L$ ,  $MD2 = H$ ,  $MD3 = H$ ,  $FS0 = L$ ,  $FS1 = L$ ,  $\overline{SDSEL} = L$ ,  $\overline{DUAL} = H$ ,  
D7 to D0 = LHLHLHLH

#### 7.2 AC Characteristics

- Switching Characteristics (1)

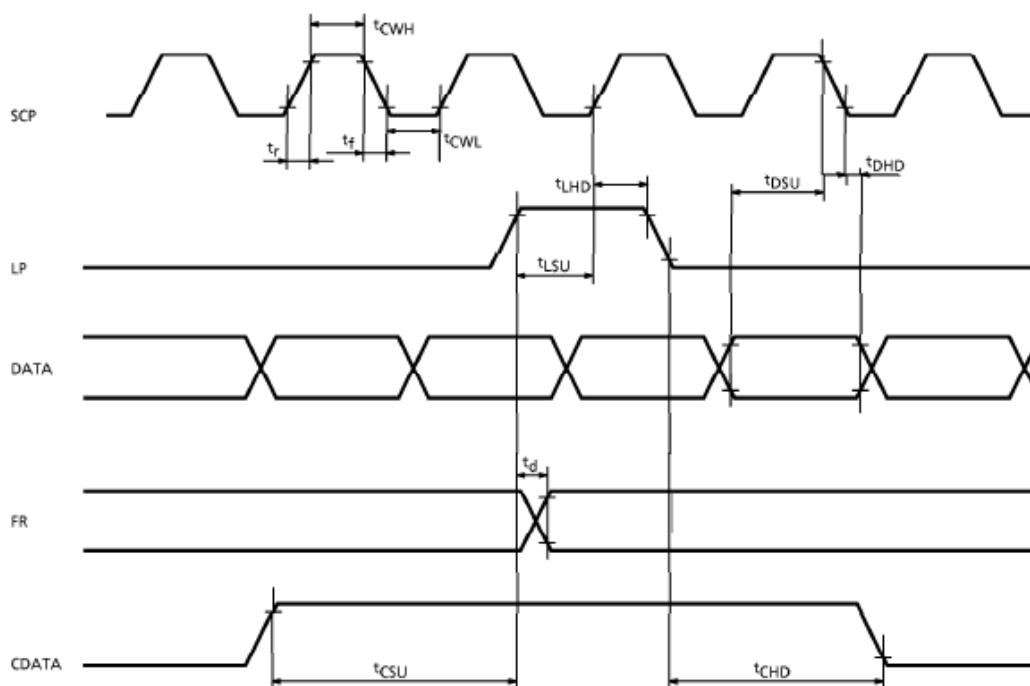

TEST CONDITIONS (Unless otherwise noted,  $V_{DD} = 5.0V \pm 10\%$ ,  $V_{SS} = 0V$ ,  $T_a = -20$  to  $70^\circ C$ )

ITEM	SYMBOL	TEST CONDITIONS	MIN	MAX	UNIT
Operating Frequency	$f_{scp}$	$T_a = -10 \sim 70^\circ C$	—	2.75	MHz
SCP Pulse Width	$t_{CWH}, t_{CWL}$	—	150	—	ns
SCP Rise / Fall Time	$t_r, t_f$	—	—	30	ns
LP Set-up Time	$t_{LSU}$	—	150	290	ns
LP Hold Time	$t_{LHD}$	—	5	40	ns
Data Set-up Time	$t_{DSU}$	—	170	—	ns
Data Hold Time	$t_{DHD}$	—	80	—	ns
FR Delay Time	$t_d$	—	0	90	ns
CData Set-up Time	$t_{CSU}$	—	450	850	ns
CData Hold Time	$t_{CHD}$	—	450	950	ns

## Switching Characteristics(2)

### Bus Timing

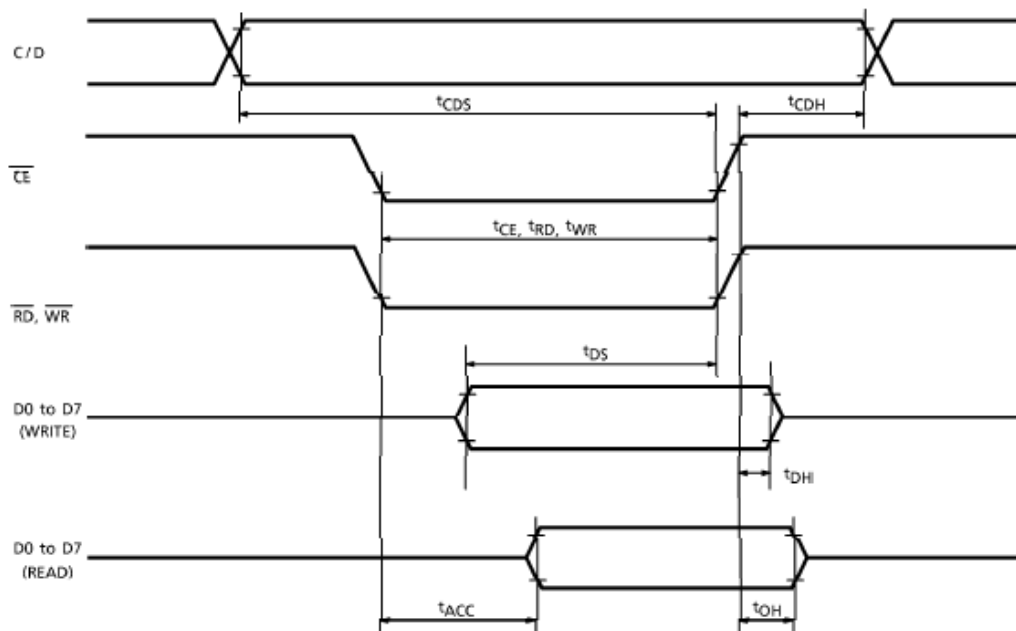

TEST CONDITIONS (Unless otherwise noted,  $V_{DD} = 5.0V \pm 10\%$ ,  $V_{SS} = 0V$ ,  $T_a = -20$  to  $75^\circ C$ )

ITEM	SYMBOL	TEST CONDITIONS	MIN	MAX	UNIT
C/D Set-up Time	$t_{CDS}$	—	100	—	ns
C/D Hold Time	$t_{CDH}$	—	10	—	ns
$\overline{CE}, \overline{RD}, \overline{WR}$ Pulse Width	$t_{CE}, t_{RD}, t_{WR}$	—	80	—	ns
Data Set-up Time	$t_{DS}$	—	80	—	ns
Data Hold Time	$t_{DH}$	—	40	—	ns
Access Time	$t_{ACC}$	—	—	150	ns
Output Hold Time	$t_{OH}$	—	10	50	ns

● Switching Characteristics (3)

(1) External RAM Read mode

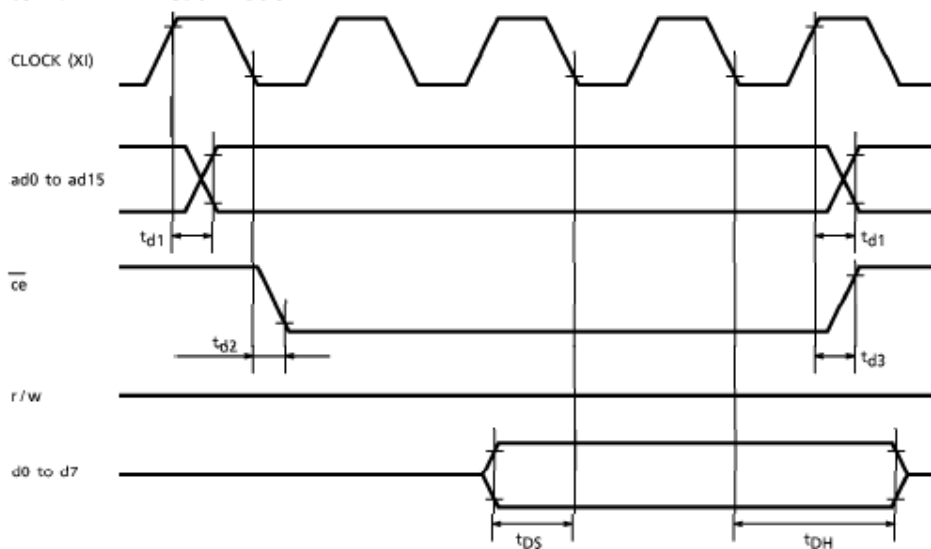

(2) External RAM Write mode

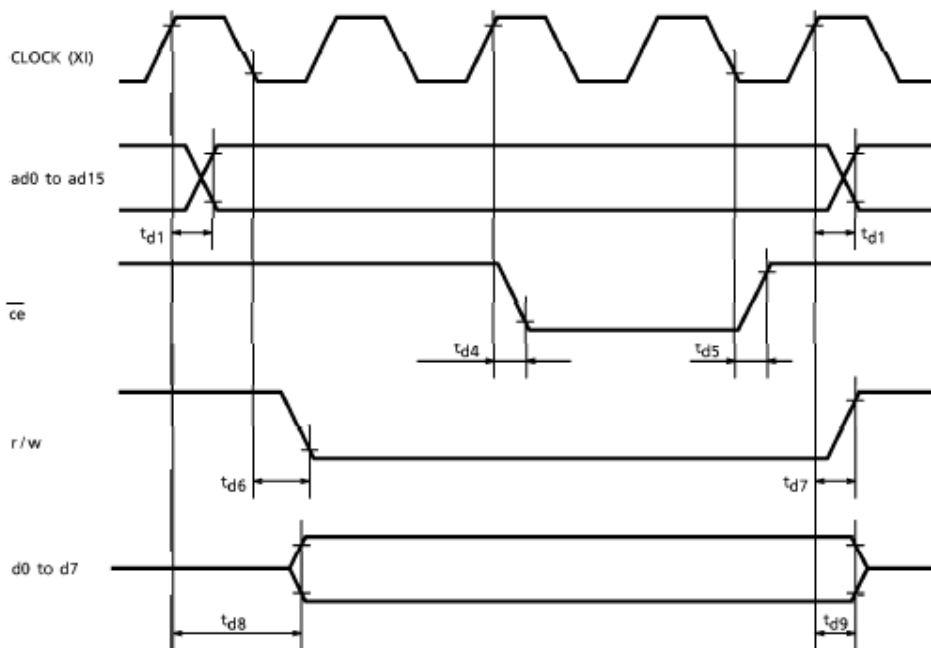

TEST CONDITIONS (Unless otherwise noted,  $V_{DD} = 5.0V \pm 10\%$ ,  $V_{SS} = 0V$ ,  $T_a = -20$  to  $70^\circ C$ )

ITEM	SYMBOL	TEST CONDITIONS	MIN	MAX	UNIT
Address Delay Time	$t_{d1}$	—	—	250	ns
ce Fall Delay Time (Read)	$t_{d2}$	—	—	180	ns
ce Rise Delay Time (Read)	$t_{d3}$	—	—	180	ns
Data Set-up Time	$t_{D5}$	—	0	—	ns
Data Hold Time	$t_{DH}$	—	30	—	ns
ce Fall Delay Time (Write)	$t_{d4}$	—	—	200	ns
ce Rise Delay Time (Write)	$t_{d5}$	—	—	200	ns
r/w Fall Delay Time	$t_{d6}$	—	—	180	ns
r/w Rise Delay Time	$t_{d7}$	—	—	180	ns
Data Stable Time	$t_{d8}$	—	—	450	ns
Data Hold Time	$t_{d9}$	—	—	200	ns

## 8.PIN ASSIGNMENT

Pin NO.	Symbol	I/O	Description
1	FG	I	bazel connect to ground
2	GND	I	Ground for Logic
3	VDD	I	Power supply for Logic
4	VLCD	I	Power supply for LCD drive
5	WR	I	Write signal for display memory
6	RD	I	Read signal for display memory
7	CE	I	Chip Enable pin for display memory for any address
8	C/D	I	/WR=L...C/D=H:Command Write C/D=L:Data Write /RD=L...C/D=H:Status Read C/D=L:Data Rad
9	NC	--	No Connection
10	RES	I	System Reset Terminal
11~~18	DB0~~DB7	I/O	Data bus
19	FS	I	Pin for Selection of Font
20	VOUT	O	DC/DC Voltage output
21	A	I	Power supply for Backlight(5.0V DC)
22	K	I	Power supply for Backlight(0V)

**9.BLOCK DIAGRAM**

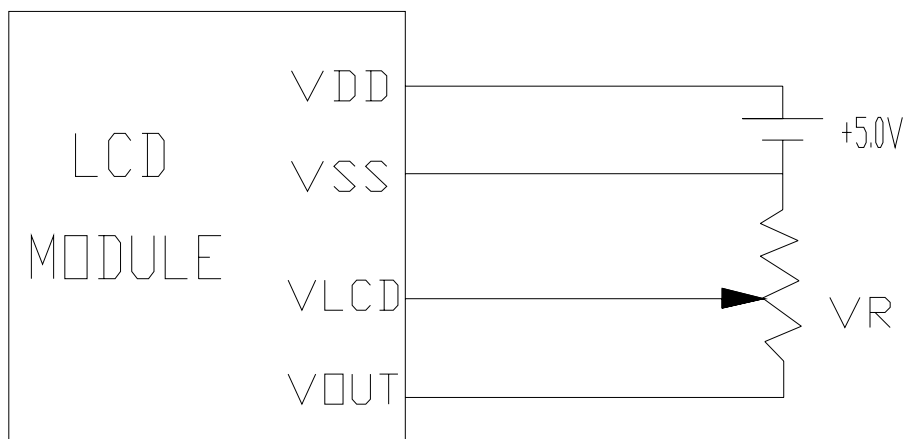
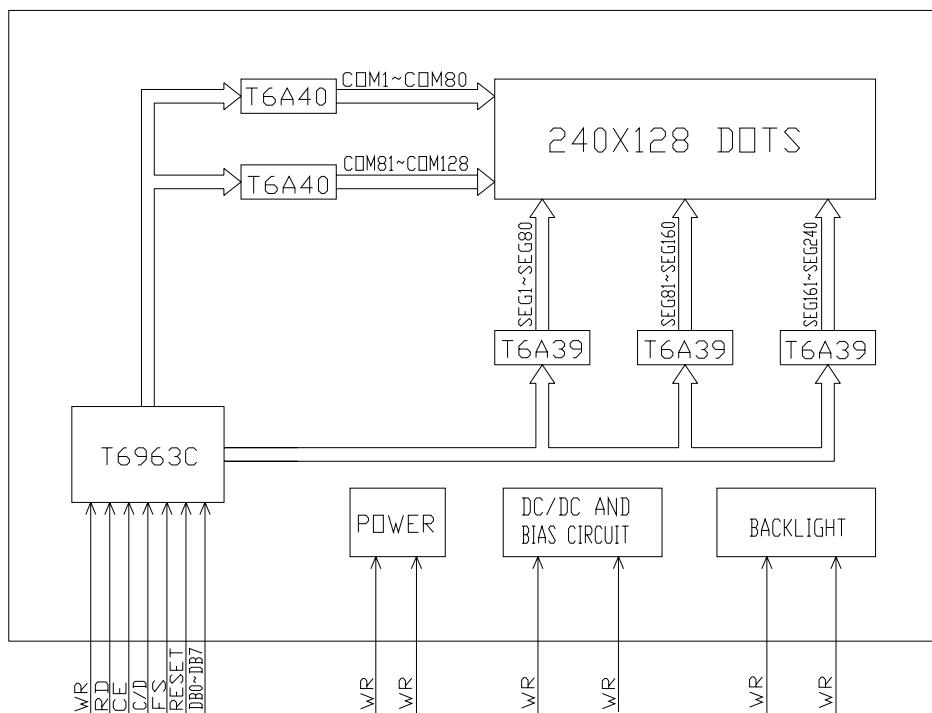

VDD-VLCD:LCD Drive Voltage  
 VR:10K~20K

**Display Control Instruction:**

**Please refer to the series of T6963C.**



10.OUTLINE DIMENSIONS

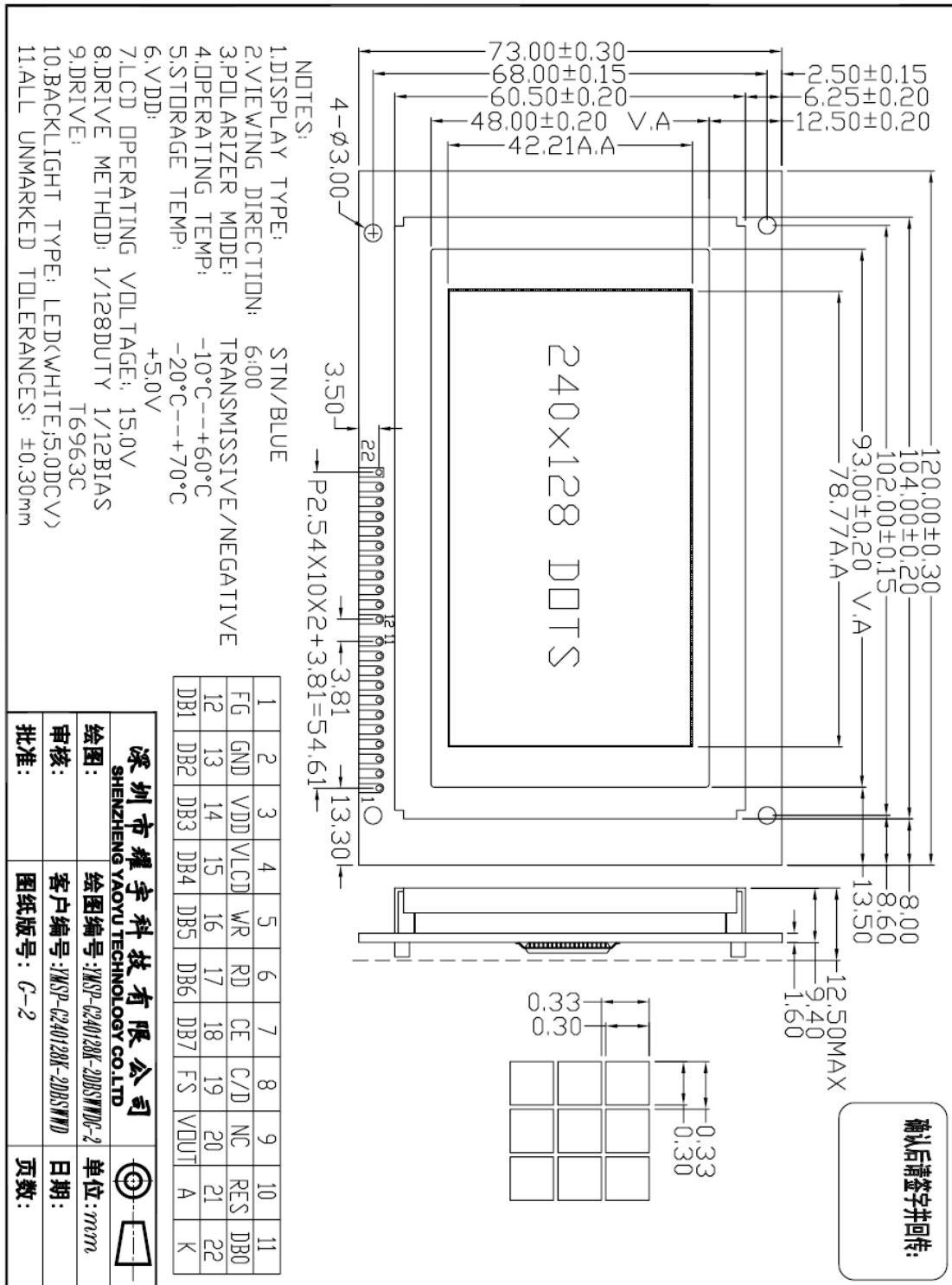

## 11. ENVIRONMENTAL ABSOLUTE MAXIMUM RATINGS

ITEM	SYMBOL	CONDITIONS	CRITERION
OPERATING TEMPERATURE	TOPR	-20°C ~ +70°C	NO DEFECT IN DISPLAYING AND OPERATIONAL FUNCTION
STORAGE TEMPERATURE	TSTG	-30°C ~ +80°C	NO DEFECT IN DISPLAYING AND OPERATIONAL FUNCTION
HUMIDITY	—	See Note	WITHOUT CONDENSATION

## 12. RELIABILITY TEST

ITEM	CONDITIONS	CRITERION
OPERATING TEMPERATURE	HIGH TEMPERATURE +70°C 240HRS	NO DEFECT IN DISPLAYING AND OPERATIONAL FUNCTION
	LOW TEMPERATURE -20°C 240HRS	
STORAGE TEMPERATURE	HIGH TEMPERATURE +80°C 240HRS	NO DEFECT IN DISPLAYING AND OPERATIONAL FUNCTION
	LOW TEMPERATURE -30°C 240HRS	
HUMIDITY	40°C 90%RH 240HRS	NO DEFECT IN DISPLAYING AND OPERATIONAL FUNCTION
VIBRATION	<ul style="list-style-type: none"> <li>• Operating Time: thirty minutes exposure for each direction (X,Y,Z)</li> <li>• Sweep Frequency: 10~55Hz (1 min)</li> <li>• Amplitude: 1.5mm</li> </ul>	NO DEFECT IN DISPLAYING AND OPERATIONAL FUNCTION
THERMAL SHOCK	-20°C (30mins) ←→ +70°C (30mins) 10 cycles	NO DEFECT IN DISPLAYING AND OPERATIONAL FUNCTION

\*NOTE: TEST CONDITION

(1) TEMPERATURE AND HUMIDITY: IF NO SPECIFICATION, TEMP. SET AT 25±2°C, HUMIDITY SET AT 60±5%RH

(2) OPERATING STATE: SAMPLES SUBJECT TO THE TESTS SHALL BE IN "OPERATING" CONDITION

### 13. PRECAUTION FOR USE

The following precautions should be followed, since this module contains precise parts.

- (1) Do not store module for an extended periods of time under the conditions of high temperature and high humidity.
- (2) Avoid using or storing the module in areas that expose it to direct sunlight or ultraviolet rays.
- (3) Use protective finger covers when handling the module to avoid scratching or staining the module.
- (4) Care should be taken not to expose the module to static electricity, because the module contains C-MOS LSI's.
- (5) The LSI is sensitive to light.  
The user's product should be designed so that LSI is not exposed to any light during operation.
- (6) During installation, cover the display area with acrylic protection plates to protect the polarizer plate and LCD cells.
- (7) Do not apply any excessive shocks to the module because the module contains sensitive LCD cells.  
Do not use a module, which has experienced strong mechanical shock.
- (8) Care should be taken when the power supply turns on as following.
  - (a) Do not apply any input signals before the supplying voltage is applied.
  - (b) Do not turn off the power supply while any input signals are applied.

## Caution

- (1) Dangerous. Do not shock glass because glass can break.
- (2) If module breaks, do not touch it directly.  
(Glass could stick or cut skin.)
- (3) Do not swallow Liquid Crystal.  
(In case of broken LCD panel, do not swallow liquid crystal even if there is no proof that liquid crystal is poisonous.)
- (4) If liquid crystal is exposed to skin, wash the area thoroughly with alcohol or soap.
- (5) When disposing of the product, please observe industrial waste disposal laws in each country and district.
- (6) In case of injury, give immediate treatment and consult with a doctor.
- (7) This product is constructed precisely. Don't disassemble or modify.

※ Neglecting this mark can cause injury to humans and damage to materials