

# SPECIFICATION



## YMSC-G25664ADYLYSD

November 14, 2007  
Version 1.





## CONTENTS

1.	BASIC SPECIFICATION-.....	1
2.	ABSOLUTE MAXIMUM RATINGS-.....	2
3.	ELECTRICAL CHARACTERISTICS-.....	3
4.	FUNCTION DESCRIPTION-.....	6
5.	INSTRUCTION SET-.....	11
6.	INTERFACE WITH MPU-.....	13
7.	INITIALIZATION -.....	14
8.	CONNECTION WITH 8051 FAMILY MPU-.....	15
9.	ELECTRO-OPTICAL CHARACTERISTICS-.....	16
10.	DIMENSIONAL OUTLINE-.....	18
11.	PRECAUTIONS FOR USE OF LCD MODULE -.....	19

## 1. BASIC SPECIFICATIONS

### 1.1 Features

Display Format	:256*64 Dots
LCD Module	:STN-Yellow Green-Positive-Transflective
Driving Method	: 1/32 Duty,1/6 Bias
Viewing Method	:6:00
Backlight	: LED, Yellow-Green
Outline Dimension	:180.0(W)X65.0(L)X10.0(T) (mm)
Viewing Area	:132.0(W)X39.0(L) (mm)
Dot Size	:0.46x0.50 (mm)
Dot Pitch	:0.50X0.54 (mm)
Weight	:150g
Controller	:ST7920-0B(GB code simplified character set)
Others	:16 Chinese charactersX4lines 8-bit,4-bit bus MPU interface Build-in 8192 Chinese characters (8X16 dots)and 126 half Width alphanumerical characters(8X16 dots) 64X16-bits character display RAM(DDRAM) 64X256-bits graphic display RAM(GDRAM) 64X16-bits character generation RAM(CGRAM)

### 1.2 Block Diagram

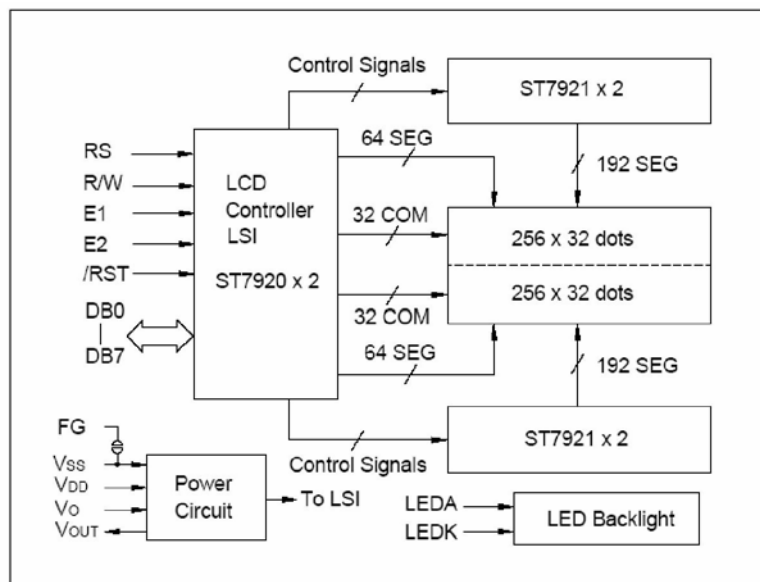

### 1.3 Terminal Functions

Pin No.	Symbol	Level	Function
1	FG	—	Frame ground
2	VSS	0V	Ground
3	VDD	+5V	Power supply for logic
4	NC	—	No connection
5	R/W	H/L	Read/Write selection for parallel mode H: Data/status read      L: Data/instruction write
6	E1	H, H -L	Chip enable signal for parallel mode      Read data when E is 'H', write data at the falling edge of E.
7	E2	H, H-L	
8	RS	H/L	Register selection for parallel mode H: Display data      L: Instruction code
9	NC	—	No connection
10	/RST	H/L	Reset signal, active "L"
'11	DB0	H/L	Data bit0
12	DB1	H/L	Data bit1
13	DB2	H/L	Data bit2
14	DB3	H/L	Data bit.3
15	DB4	H/L	Data bit4
16	DB5	H/L	Data bit5
17	DB6	H/L	Data bit6
18	DB7	H/L	Data bit.7
19	NC	—	No connection
20	NC	—	No connection

### 2 ABSOLUTE MAXIMUM RATINGS

Item	Symbol	Min.	Max.	Unit
Supply Voltage(Logic)	VDD-VSS	-0.3	5.5	V
Supply Voltage(LCD)	Vo-Vss	-0.3	7.0	V
Input Voltage	Vi	-0.3	VDD+0.3	V
Operating Temp.	Topr	-20	70	°C
Storage Temp.	Tstg	-30	30	°C

### 3. ELECTRICAL CHARACTERISTIC

#### 3.1 DC Characteristics

(VDD=5.0V±5%, Ta=25°C)

Item	Symbol	Condition	Min.	Typ.	Max.	Unit
Supply Voltage (Logic)	VDD		4.5	5.0	5.5	V
Supply Voltage (LCD Drive)	Vo-Vss		--	6.5	--	V
Input High Voltage	VIH		0.7VDD	--	VDD	V
Input Low Voltage	VIL		-0.3	--	0.6	V
Output High Voltage	VOH	IOH=-0.1mA	0.8VDD	--	VDD	V
Output Low Voltage	VOL	IOL=0.1mA	0	--	0.4	V
Supply Current (Logic)	IDD	VDD=5.0V	--	10.0	15.0	V

#### 3.2 Parallel Mode AC Characteristic

(VDD=5.0V±5%, Ta=25°C)

Characteristic	Symbol	Min.	Typ.	Max.	Unit
E Cycle	tc	1200	--	--	ns
E Pulse Width	tPH	140	--	--	ns
E Rise Time	tR	--	--	25	ns
E Fall Time	tF	--	--	25	ns
Address Setup Time	tAS	10	--	--	ns
Address Hold Time	tAH	20	--	--	ns
Data Setup Time	TDSW	40	--	--	ns
Data Delay Time	tDDR	--	--	100	ns
Data Hold Time(Write)	tH	20	--	--	ns
Data Hold Time(Read)	tH	20	--	--	ns

● Parallel Mode Write Timing Diagram

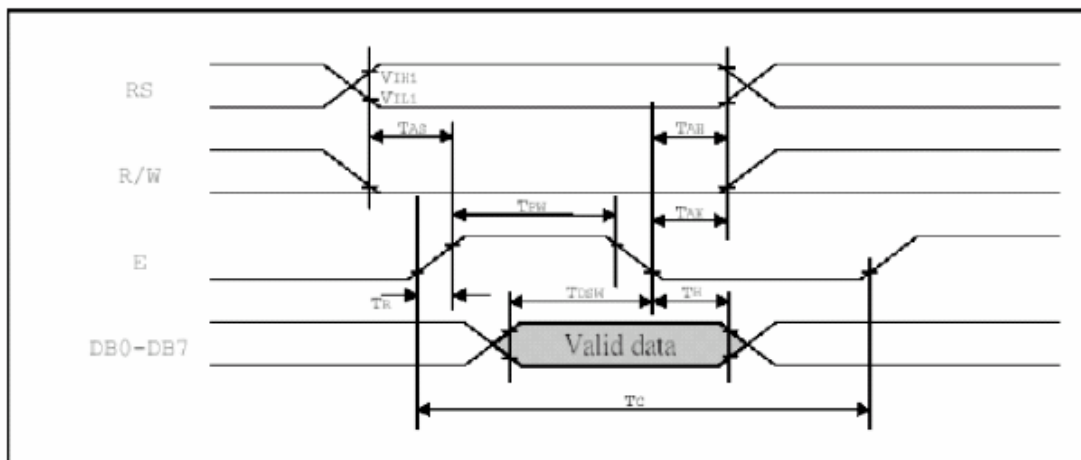

● Parallel Mode Read Timing Diagram

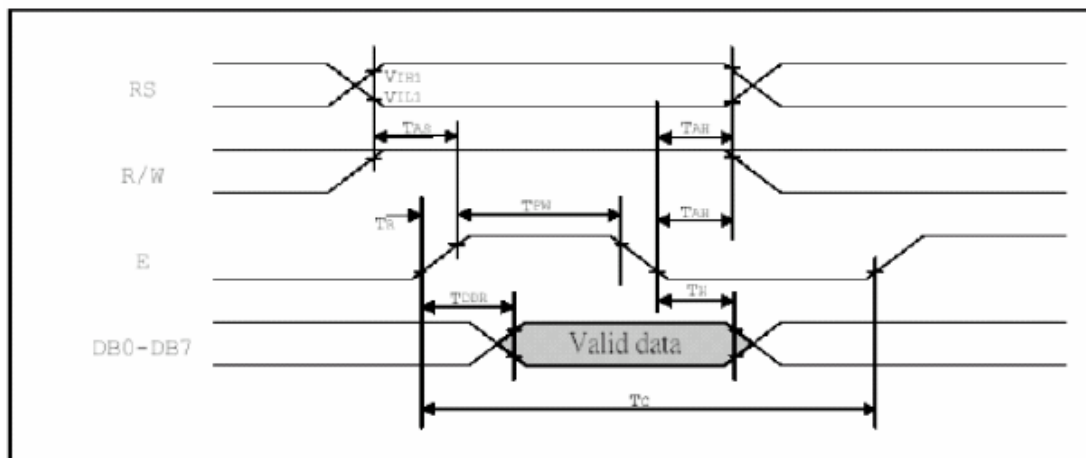

3.3 LED Backlight Characteristics ( $T_a=25^\circ\text{C}$ )

Item	Symbol	Condition	Min.	Typ.	Max.	Unit
Forward Voltage	$V_f$			4.2	4.2	V
Forward Current	$I_f$	$V_f=4.2\text{V}$	-	TBD	--	mA
Luminance	$L_v$	--	--	-	--	$\text{cd/m}^2$
Color	Yellow-Green					

### 3.4 Power Supply

#### 1) Power Supply for Fixed Contrast

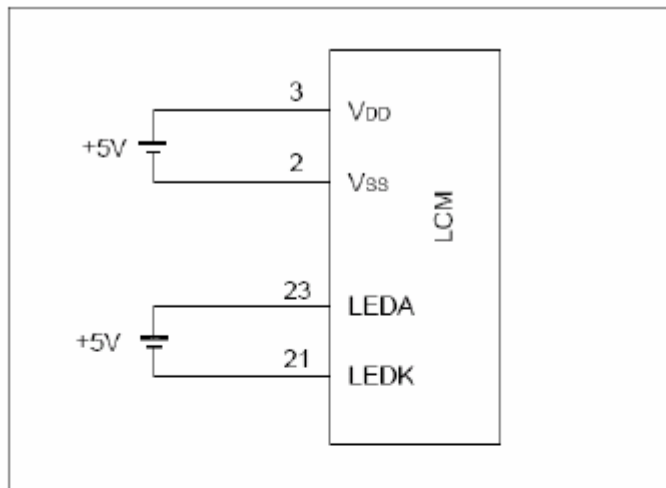

#### 2) Power Supply for Adjustable Contrast

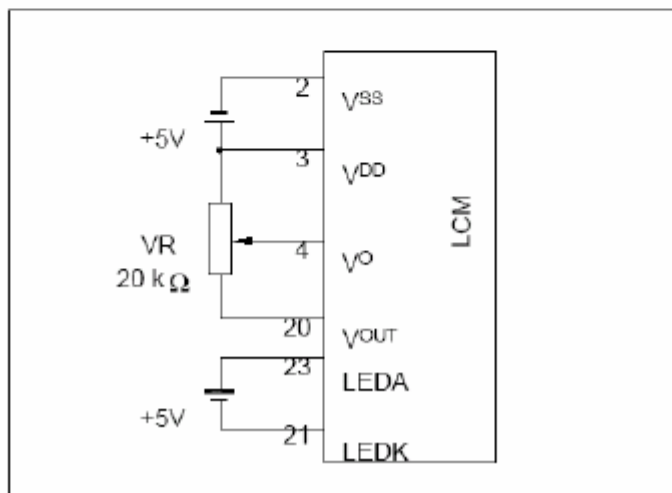

## 4. FUNCTION DESCRIPTION

### 4.1 System Interface

ST7920 supports 3 kinds of bus interface to MPU. 8 bits parallel, 4 bits parallel and clock synchronized serial interface. Parallel interface and serial interface is selected by PSB terminal. 8 bit / 4 bit interface is selected by function set instruction DL bit. Two 8 bit registers (Data Register DR, Instruction Register IR) are used in ST7920's write and read operation. Data Register ( DR ) can access DDRAM/CGRAM/GDRAM and IRAM's data through the address pointer implemented by Address Counter (AC). Instruction Register (IR) stores the instruction by MPU to ST7920.

4 modes of read/write operation specified by RS and RW :

RS	RW	Description
L	L	MPU write instruction to instruction register ( IR )
L	H	MPU read busy flag ( BF ) and address counter ( AC )
H	L	MPU write data to data register ( DR )
H	H	MPU read data from data register ( DR )

### 4.2 Busy Flag (BF)

Internal operation is in progress when BF="1", ST7920 is in busy state. No new instruction will be accepted until BF="0". MPU must check BF to determine whether the internal operation is finished and new instruction can be sent.

### 4.3 Address Counter (AC)

Address counter (AC) is used for address pointer of DDRAM/CGRAM/IRAM/GDRAM. AC can be set by instruction and after data read or write to the memories AC will increase or decrease by 1 according to the setting in "entry mode set". When RS="0" and RW="1" and E="1" the value of AC will output to DB6-DB0.

### 4.4 16x16 Character Generator ROM (CGROM) and 8x16 Half Width ROM (HCGROM)

ST7920 provides character generator ROM supporting 8192 16x16 character fonts and 126 8x16 alphanumeric characters. It is easy to support multi languages application such as Chinese and English. Two consecutive bytes are used to specify one 16x16 character or two 8x16 half-width characters. Character codes are written into DDRAM and the corresponding fonts are mapped from CGROM or HCGROM to the display drivers.

### 4.5 Character Generator RAM (CGRAM)

ST7920 provides RAM to support user-defined fonts. Four sets of 16x16 bit map area are available. These user-defined fonts are displayed the same ways as CGROM fonts through writing character cod data to DDRAM.

#### 4.6 Display Data RAM (DDRAM)

There are 64x2 bytes for display data RAM area which can store display data for 16 characters (16x16) by 4 lines or 32 characters(8x16) by 4 lines. However, only 2 lines can be displayed at a time. Character codes stored in DDRAM point to the fonts specified by CGROM, HCGROM and CGRAM. ST7920 can display half width HCGROM fonts, user-defined CGRAM fonts and full 16x16 CGROM fonts. The font type is selected by the data code automatically. Data codes 0000H to 0006H are for CGRAM user-defined fonts. Data codes 02H to 7FH are for half width alphanumeric fonts. Data codes A140 to D75F are for BIG5 code and A1A0 to F7FF are for GB code.

- 1) Display HCGROM fonts : Write 2 bytes data to DDRAM to display two 8x16 fonts. Each byte represents 1 character font. The data of each byte is 02H to 7FH.
- 2) Display CGRAM fonts : Write 2 bytes data to DDRAM to display one 16x16 font. Only 0000H, 0002H, 0004H, 0006H are allowed.
- 3) Display CGROM fonts : Write 2 bytes data to DDRAM to display one 16x16 font. A140H to D75FH are for BIG5 code, A1A0H to F7FFH are for GB code.

Higher byte (D15-D8) is written first and then lower byte (D7-D0).

CGRAM fonts and CGROM fonts can only be displayed in the start position of each address.

80	81	82	83	84	85	86	87	88	89	8A	8B	8C	8D	8E	8F
H L	H L	H L	H L	H L	H L	H L	H L	H L	H L	H L	H L	H L	H L	H L	H L
S	i	t	r	o	n	i	x		S	T	7	9	2	0	
矽	創	電	子	.	.	中	文	編	碼	(	正	確	)		
矽	創	電	子	.	.	.	中	文	編	碼					

Incorrect position



#### 4.7 Graphic RAM (GDRAM)

Graphic display RAM supports 64x256 bits bit-mapped memory space. GDRAM address is set by writing 2 consecutive bytes for vertical address and horizontal address. Two-byte data write to GDRAM for one address. Address counter will automatically increase by one for the next two-byte data. The procedure is as followings.

1. Set vertical address (Y) for GDRAM
2. Set horizontal address (X) for GDRAM
3. Write D15-D8 to GDRAM (first byte)
4. Write D7-D0 to GDRAM (second byte)

● 8x16 Half-width Characters

H/L	0	1	2	3	4	5	6	7	8	9	A	B	C	D	E	F
0		☺	☹	♥	♠	♣	♣	•	◐	◑	◓	♂	♀	♂	♂	✳
1	▶	◀	↑	!!	¶	§	—	‡	†	↓	→	←	└	↕	▲	▼
2		!	"	#	\$	%	&	'	(	)	*	+	,	-	.	/
3	0	1	2	3	4	5	6	7	8	9	:	;	<	=	>	?
4	@	A	B	C	D	E	F	G	H	I	J	K	L	M	N	O
5	P	Q	R	S	T	U	V	W	X	Y	Z	[	\	]	^	_
6	'	a	b	c	d	e	f	g	h	i	j	k	l	m	n	o
7	p	q	r	s	t	u	v	w	x	y	z	{		}	~	△

● DDRAM Data (Character Code), CGRAM Data Address Map

DDRAM data (char. code)				CGRAM Addr.				CGRAM data (higher byte)				CGRAM data (lower byte)																					
B15~ B4	B3	B2	B1	B0	B5	B4	B3	B2	B1	B0	D15	D14	D13	D12	D11	D10	D9	D8	D7	D6	D5	D4	D3	D2	D1	D0							
0	X	00	X	00	0	0	0	0	0	0	0	0	0	0	1	0	0	0	0	1	1	0	0	0	0	0	0						
					0	0	0	1	1	1	1	1	1	0	0	1	0	0	0	0	0	0	0	0	0	0	0	0	0	0	0		
					0	0	1	0	0	0	0	1	0	0	0	0	0	0	0	1	0	0	0	0	1	0	0	0	1	0	0	0	
					0	0	1	1	0	0	0	0	1	0	0	0	0	0	0	1	1	1	1	1	1	0	0	0	0	0	0	0	
					0	1	0	0	0	0	0	1	0	0	1	0	0	1	0	0	1	0	0	1	0	0	0	0	1	0	0	0	
					0	1	0	1	0	0	1	1	1	1	0	0	1	0	0	1	0	0	0	1	0	0	0	0	1	0	0	0	
					0	1	1	0	0	1	1	0	0	1	0	1	0	1	0	1	0	1	0	0	1	0	0	0	1	0	0	0	
					0	1	1	1	1	0	1	0	0	0	1	0	0	1	0	0	1	0	0	1	0	0	0	1	0	0	0	0	
					1	0	0	0	0	0	0	1	0	0	1	0	0	0	0	1	0	1	0	0	0	0	0	1	0	0	0	0	
					1	0	0	1	0	0	1	0	0	1	0	0	1	0	0	0	0	0	0	0	0	1	0	0	0	0	0	0	
					1	0	1	0	0	0	1	0	0	1	0	0	1	0	0	0	0	0	0	0	1	0	0	0	0	0	0	0	
					1	0	1	1	0	0	1	1	1	1	0	0	0	0	0	1	0	0	0	0	1	0	0	0	0	0	0	0	
					1	1	0	0	0	0	1	0	0	1	0	0	1	0	0	0	0	0	0	1	0	0	0	0	0	0	0	0	
					1	1	1	0	0	0	0	0	0	0	0	0	0	0	0	0	0	0	0	0	0	0	0	0	0	0	0	0	
					1	1	1	1	0	0	0	0	0	0	0	0	0	0	0	0	0	0	0	0	0	0	0	0	0	0	0	0	
					0	X	01	X	01	0	0	0	0	0	0	0	0	0	1	1	0	0	0	0	0	0	0	0	0	1	1	0	
0	0	0	1	0						0	0	1	1	0	1	0	0	0	0	0	0	0	0	0	0	0	1	0	0	0			
0	0	1	0	0						0	1	0	0	0	0	1	0	0	1	0	0	1	1	0	1	0	0	1	0	0	0		
0	0	1	1	0						1	0	1	1	1	0	1	1	0	1	1	0	1	0	0	1	0	0	1	0	0	0		
0	1	0	0	1						0	0	0	0	0	0	0	1	0	1	0	0	1	0	0	1	0	0	1	0	0	0		
0	1	0	1	0						1	1	1	1	1	1	0	0	1	0	0	1	0	0	1	0	0	1	0	0	1	0	0	
0	1	1	0	0						1	0	0	0	0	0	1	0	0	1	0	0	1	0	0	1	0	0	1	0	0	0		
0	1	1	1	0						1	1	1	1	1	1	0	0	1	0	0	1	0	0	1	0	0	1	0	0	1	0	0	
1	0	0	0	0						1	0	0	0	0	0	1	0	0	0	0	1	0	0	1	0	0	1	0	0	1	0	0	
1	0	0	1	0						1	1	1	1	1	1	0	0	1	0	0	1	0	0	1	0	0	1	0	0	1	0	0	
1	0	1	0	0						1	0	0	0	0	0	0	0	0	0	0	0	1	0	0	1	0	0	1	0	0	0		
1	0	1	1	0						1	1	1	1	1	1	1	0	0	0	0	1	0	0	0	0	0	1	0	0	1	0	0	
1	1	0	0	1						0	1	0	0	0	0	0	1	0	1	0	0	1	0	0	1	0	0	1	0	0	1	0	0
1	1	0	1	0						1	1	1	1	1	1	1	0	0	1	1	0	0	1	1	1	0	0	1	1	1	0	0	
1	1	1	0	1						0	1	0	0	0	0	0	1	0	0	0	0	1	0	0	0	1	0	0	0	1	0	0	
1	1	1	1	0						0	0	0	0	0	0	0	0	0	0	0	0	0	0	0	0	0	0	0	0	0	0	0	

Note :

1. DDRAM data (character code) bit1 and bit2 are the same as CGRAM address bit4 and bit5.
2. CGRAM address bit0 to bit3 specify total 16 rows. Row16 is for cursor display. The data in row 16 will be logical OR to the cursor.
3. CGRAM data for each address is 16 bits.
4. DDRAM data to select CGRAM bit4 to bit15 must be "0". Bit0 and bit3 value are "don't care".

● GDRAM Display Coordinates and Corresponding Address

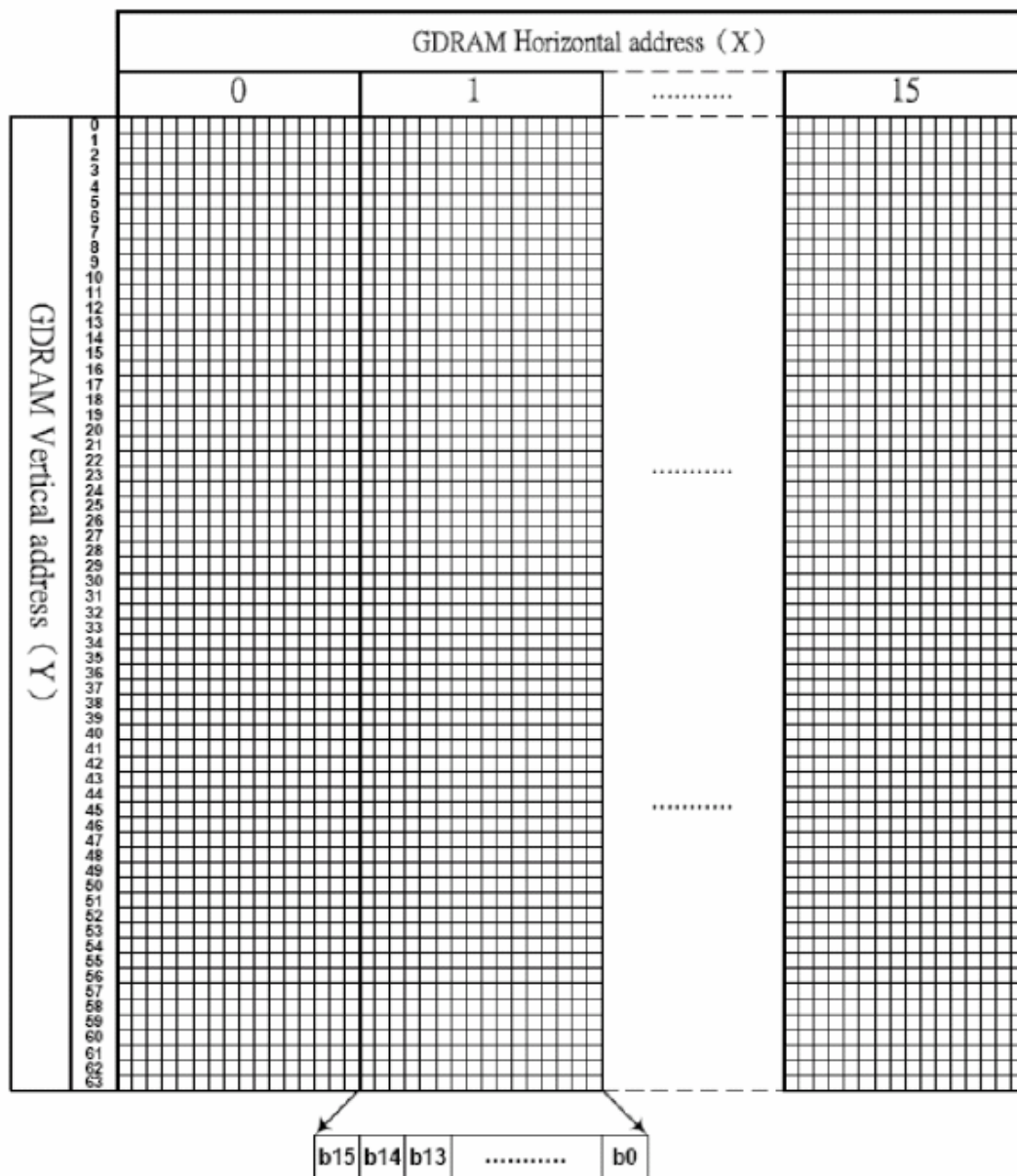

## 5. INSTRUCTION SET

ST7920 offers basic instruction set and extended instruction set :

### Instruction set 1: (RE=0: basic instruction)

Ins	code											Description	Exec time (540KHZ)
	RS	RW	DB7	DB6	DB5	DB4	DB3	DB2	DB1	DB0			
CLEAR	0	0	0	0	0	0	0	0	0	0	1	Fill DDRAM with "20H", and set DDRAM address counter (AC) to "00H"	1.6 us
HOME	0	0	0	0	0	0	0	0	0	1	X	Set DDRAM address counter (AC) to "00H", and put cursor to origin ; the content of DDRAM are not changed	72us
ENTRY MODE	0	0	0	0	0	0	0	0	1	I/D	S	Set cursor position and display shift when doing write or read operation	72us
DISPLAY ON/OFF	0	0	0	0	0	0	0	1	D	C	B	D=1: display ON C=1: cursor ON B=1: blink ON	72 us
CURSOR DISPLAY CONTROL	0	0	0	0	0	1	S/C	R/L	X	X		Cursor position and display shift control ; the content of DDRAM are not changed	72 us
FUNCTION SET	0	0	0	0	1	DL	X	0	RE	X	X	DL=1 8-BIT interface DL=0 4-BIT interface <u>RE=1: extended instruction</u> <u>RE=0: basic instruction</u>	72 us
SET CGRAM ADDR.	0	0	0	1	AC5	AC4	AC3	AC2	AC1	AC0		Set CGRAM address to address counter (AC) <u>Make sure that in extended instruction SR=0 (scroll or RAM address select)</u>	72 us
SET DDRAM ADDR.	0	0	1	0	AC5	AC4	AC3	AC2	AC1	AC0		Set DDRAM address to address counter (AC) AC6 is fixed to 0	72 us
READ BUSY FLAG (BF) & ADDR.	0	1	BF	AC6	AC5	AC4	AC3	AC2	AC1	AC0		Read busy flag (BF) for completion of internal operation, also Read out the value of address counter (AC)	0 us
WRITE RAM	1	0	D7	D6	D5	D4	D3	D2	D1	D0		Write data to internal RAM (DDRAM/CGRAM/IRAM/GDRAM)	72 us
READ RAM	1	1	D7	D6	D5	D4	D3	D2	D1	D0		Read data from internal RAM (DDRAM/CGRAM/IRAM/GDRAM)	72 us

**Instruction set 2: (RE=1: extended instruction)**

Inst.	code										description	Exec. time (540KHZ)
	RS	RW	DB7	DB6	DB5	DB4	DB3	DB2	DB1	DB0		
STANDBY	0	0	0	0	0	0	0	0	0	1	Enter stand by mode, any other instruction can terminate (Com1..32 halted, only Com33 ICON can display)	72 us
SCROLL or RAM ADDR. SELECT	0	0	0	0	0	0	0	0	1	SR	SR=1: enable vertical scroll position SR=0: enable IRAM address ( <b>extended instruction</b> ) SR=0: enable CGRAM address( <b>basic instruction</b> )	72 us
REVERSE	0	0	0	0	0	0	0	1	R1	R0	Select 1 out of 4 line ( in DDRAM) and decide whether to reverse the display by toggling this instruction <b>R1,R0</b> initial value is 00	72 us
EXTENDED FUNCTION SET	0	0	0	0	1	DL	X	1	RE	G	DL=1 8-BIT interface DL=0 4-BIT interface <b>RE=1: extended instruction set</b> <b>RE=0: basic instruction set</b> G=1 :graphic display ON G=0 :graphic display OFF	72 us
SET IRAM or SCROLL ADDR	0	0	0	1	AC5	AC4	AC3	AC2	AC1	AC0	SR=1: AC5-AC0 the address of vertical scroll SR=0: AC3-AC0 the address of ICON RAM	72 us
SET GRAPHIC RAM ADDR.	0	0	1	0	0	0	AC3	AC2	AC1	AC0	Set CDRAM address to address counter ( AC ) First set vertical address and the horizontal address by consecutive writing Vertical address range AC5...AC0 Horizontal address range AC3...AC0	72 us

**Note :**

1. Make sure that ST7920 is not in busy state by reading the busy flag before sending instruction or data. If use delay loop instead please make sure the delay time is enough. Please refer to the instruction execution time.
2. "RE" is the selection bit of basic and extended instruction set. Each time when altering the value of RE it will remain. There is no need to set RE every time when using the same group of instruction set.

## 6. INTERFACE WITH MPU

### 6.1 Parallel Interface

LG256641 can work in parallel mode. It can select 8 bit or 4-bit bus interface by function set instruction DL control bit. MPU can control RS, RW, E and DB0 to DB7 pins to complete the data transmission.

In 4-bit transfer mode, every 8 bits data or instruction is separated into 2 parts. Higher 4 bits (DB7-DB4) data will transfer first and placed into data pins (DB7-DB4). Lower 4 bits (DB3-DB0) data will transfer second and placed into data pins (DB7-DB4). (DB3-DB0) data pins are not used.

8 bit interface:

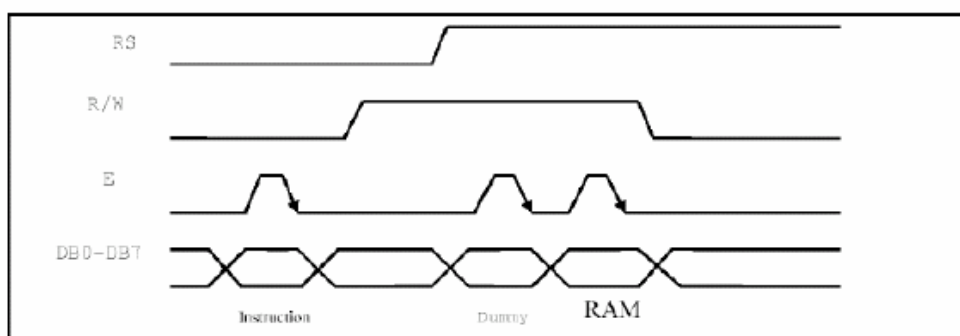

4 bit interface:

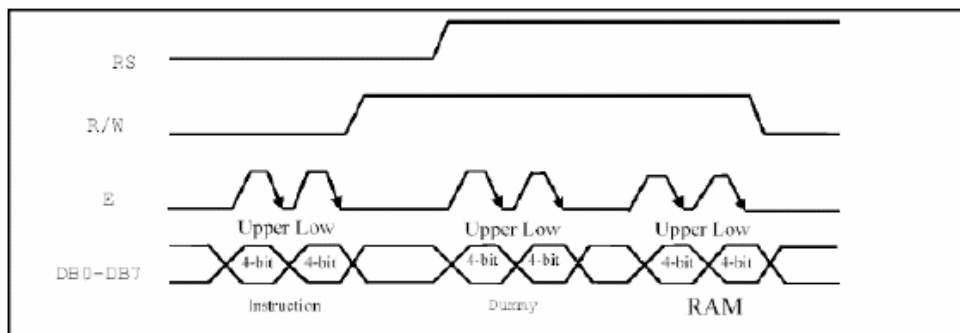

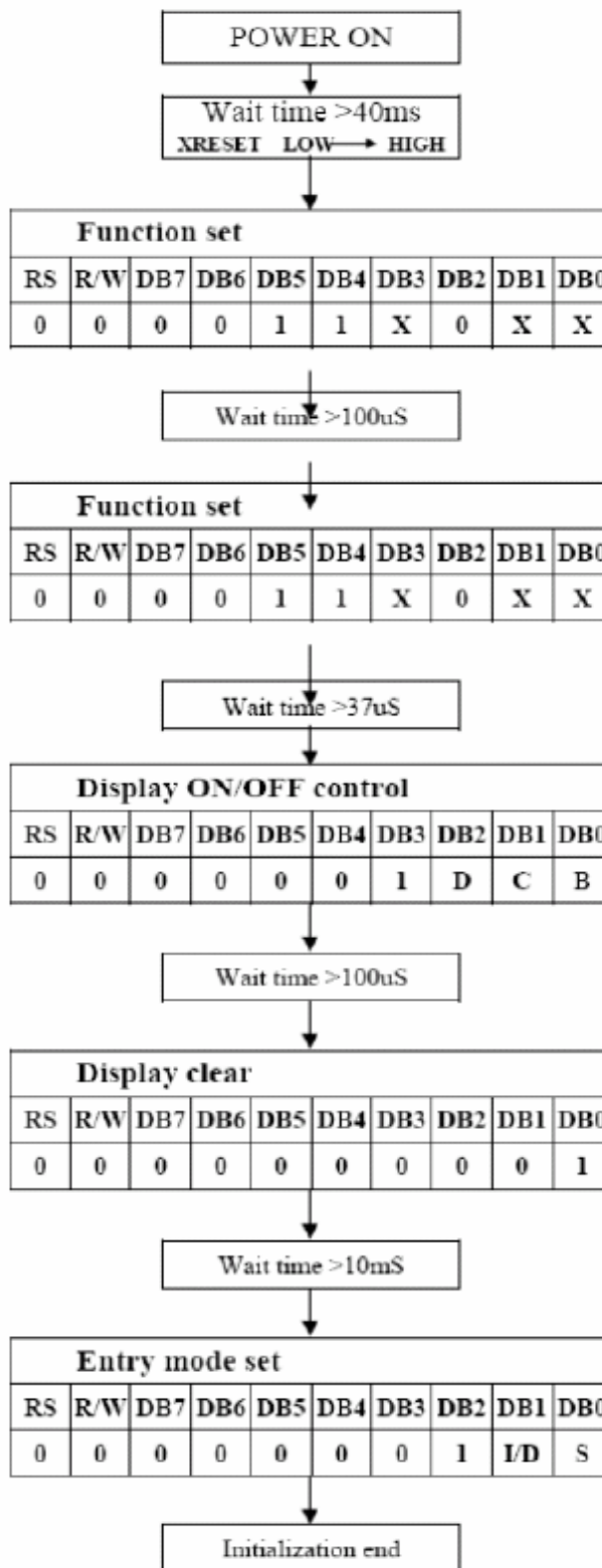
**7. INITIALIZATION**
**8 bit interface :**

8. CONNECTION WITH 8051 FAMILY MPU

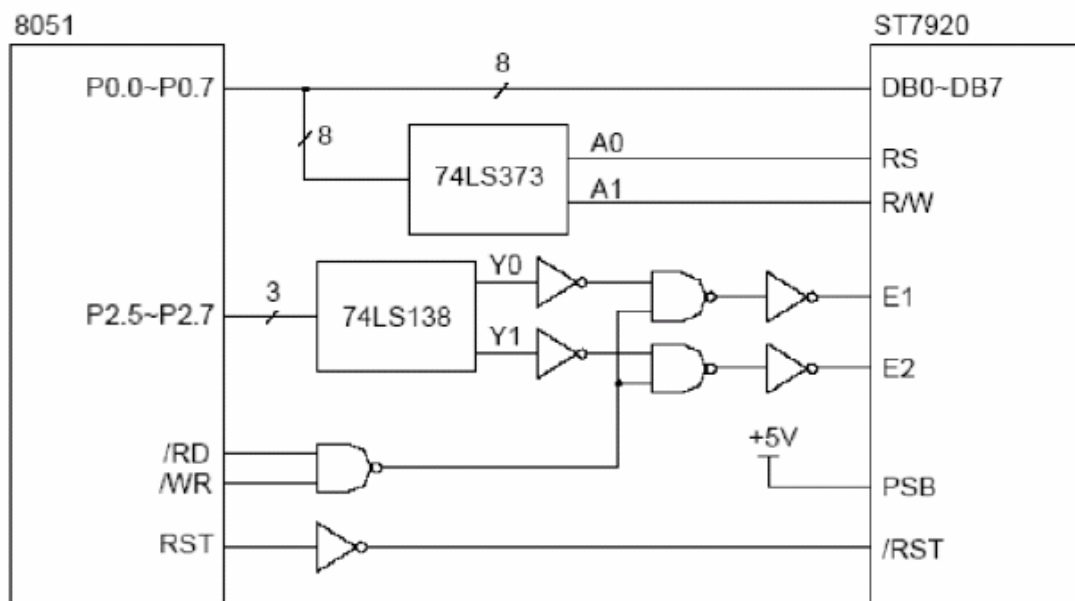

a. Application Circuit 1

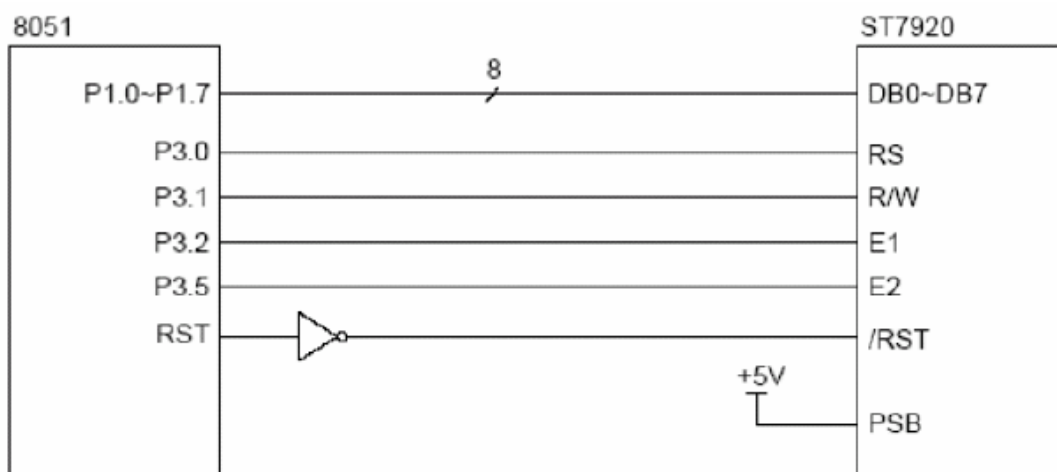

b. Application Circuit 2

9. ELECTRO-OPTICAL CHARACTERISTICS (Ta=25°C)

Item	Symbol	Condition	Min.	Typ.	Max.	Unit	Note
View Angle	$\phi 2-\phi 1$	$K \geq 2, \theta = 0^\circ$	--	70	--	Deg	Note1, Note2
Contrast	K	$\Phi = 0^\circ, \theta = 0^\circ$	3	--	--	--	Note3
Response Time	tr (rise)	$\Phi = 0^\circ, \theta = 0^\circ$	--	250	--	ms	Note3
	tf (fall)	$\Phi = 0^\circ, \theta = 0^\circ$	--	250	--	ms	

Note1: Definition of Viewing Angle  $\theta, \Phi$

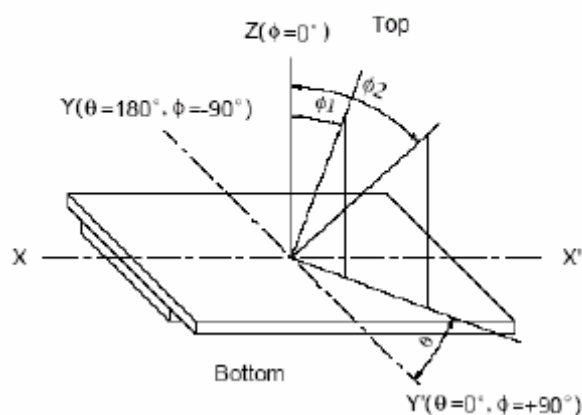

Note2: Definition of viewing Angle Range:  $\phi 1, \phi 2$

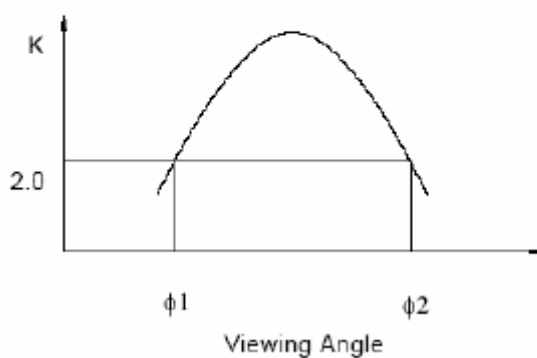

**Note3: Definition of Contrast**

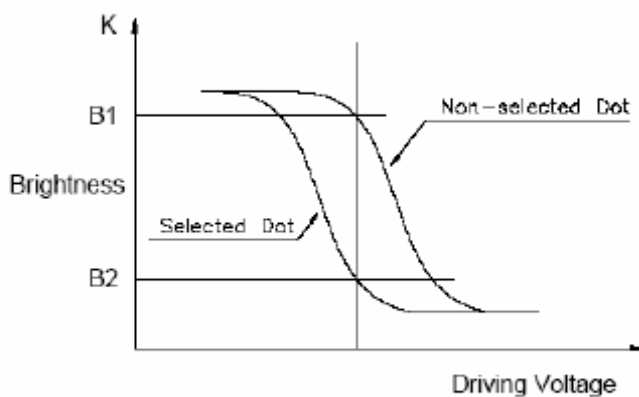

$$\text{Contrast} = \frac{\text{Brightness of non-selected dot (B1)}}{\text{Brightness of selected dot (B2)}}$$

**Note4: Definition of Response Time**

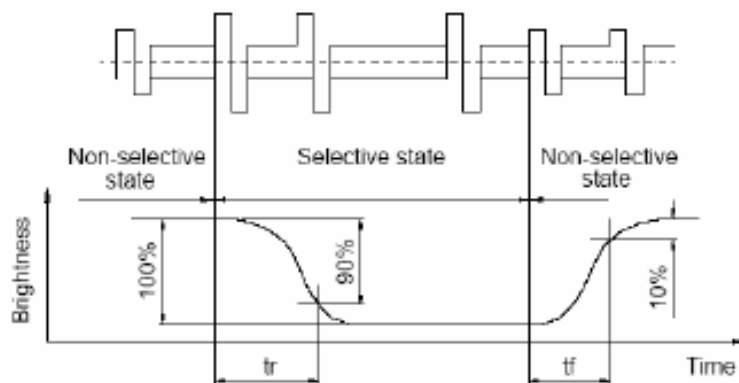

10. DIMENSIONAL OUTLINE

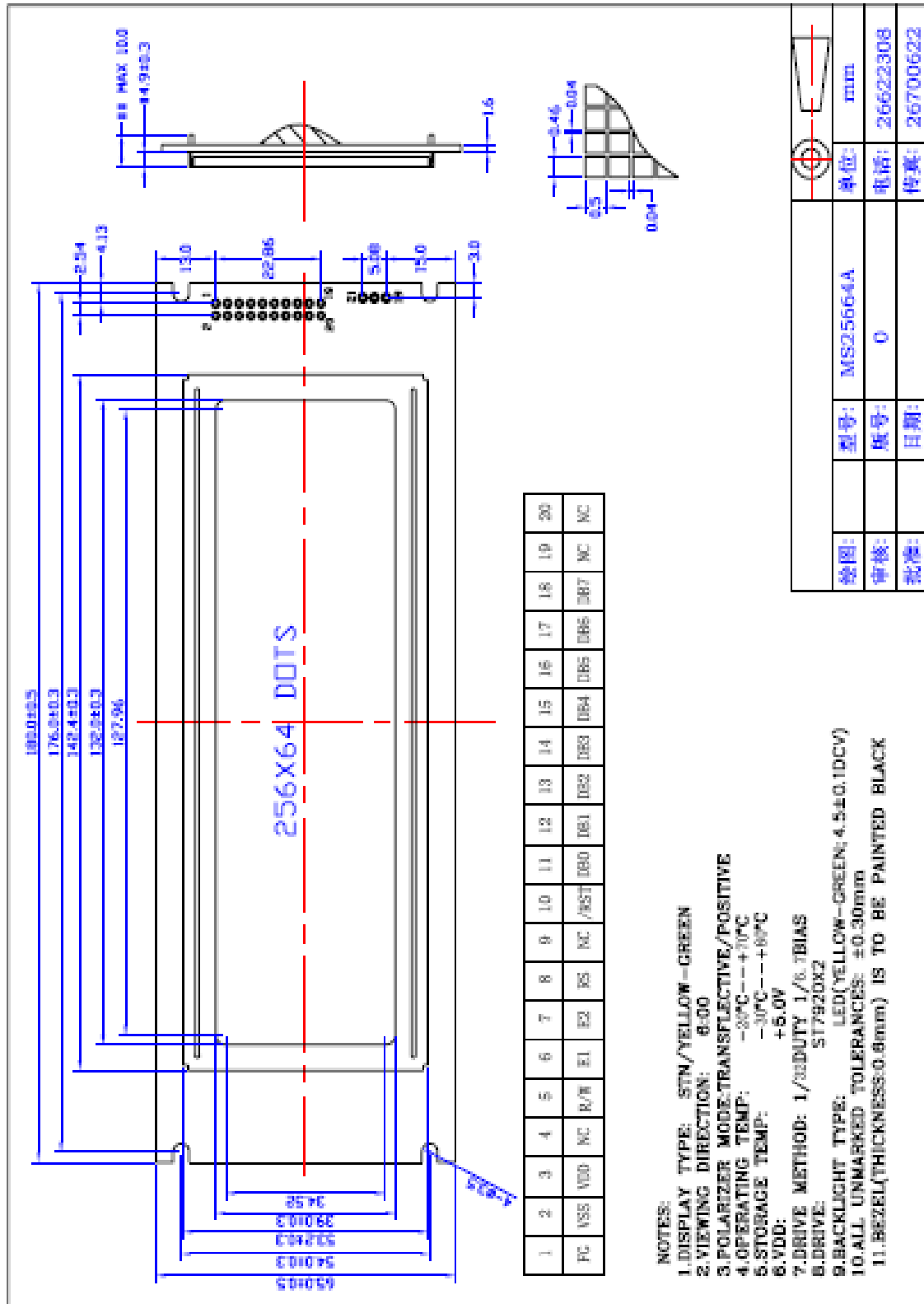

## 11. PRECAUTIONS FOR USE OF LCD MODULE

### 11.1 Handling Precautions

- 1) The display panel is made of glass. Do not subject it to a mechanical shock by Dropping it from a high place, etc.
- 2) If the display panel is damaged and the liquid crystal substance inside it leaks out, be sure not to get any in your mouth. If the substance comes into contact with your Skin or clothes, promptly wash it off using soap and water.
- 3) Do not apply excessive force on the surface of display or the adjoining areas of LCD module since this may cause the color tone to vary.
- 4) The polarizer covering the display surface of the LCD module is soft and easily Scratched. Handle this polarizer carefully.
- 5) If the display surface of LCD module becomes contaminated, blow on the Surface and gently wipe it with a soft dry cloth. If it is heavily contaminated, moisten Cloth with one of the following solvents.
  - Isopropyl alcohol
  - Ethyl alcoholSolvents other than those mentioned above may damage the polarizer.  
Especially, do not use the following:
  - Water
  - Ketone
  - Aromatic Solvents
- 6) When mounting the LCD module make sure that it is free of twisting, warping, and Distortion. Distortion has great influence upon display quality. Also keep the Stiffness enough regarding the outer case.
- 7) Be sure to avoid any solvent such as flux for soldering never stick to Heat-Seal. Such solvent on Heat-Seal may cause connection problem of heat-Seal and TAB.
- 8) Do not forcibly pull or bend the TAB I/O terminals.
- 9) Do not attempt to disassemble or process the LCD module.
- 10) NC terminal should be open. Do not connect anything.
- 11) If the logic circuit power is off, do not apply the input signals.
- 12) To prevent destruction of the elements by static electricity, be careful to maintain an optimum work environment.
  - Be sure to ground the body when handling the LCD module.
  - Tools required for assembly, such as soldering irons, must be properly grounded.
  - To reduce the amount of static electricity generated, do not conduct assembly and other work under dry conditions.
  - The LCD module is coated with a film to protect the display surface. Exercise care when peeling off this protective film since static electricity may be generated.

## 11.2 Storage Precautions

- 1) When storing the LCD module, avoid exposure to direct sunlight or to the light of Fluorescent lamps and high temperature/high humidity. Whenever possible, the LCD module should be stored in the same conditions in which they were shipped from Our company.
- 2) Exercise care to minimize corrosion of the electrodes. Corrosion of the electrodes is accelerated by water droplets or a current flow in a high humidity environment.

## 11.3 Design Precautions

- 1) The absolute maximum ratings represent the rated value beyond which LCD module can not exceed. When the LCD modules are used in excess of this rated value, their operating characteristics may be adversely affected.
- 2) To prevent the occurrence of erroneous operation caused by noise, attention must be paid to satisfy VIL, VIH specification values, including taking the precaution of using signal cables that are short.
- 3) The liquid crystal display exhibits temperature dependency characteristics. Since recognition of the display becomes difficult when the LCD is used outside its designated operating temperature range, be sure to use the LCD within this range. Also, keep in mind that the LCD driving voltage levels necessary for clear displays will vary according to temperature.
- 4) Sufficiently notice the mutual noise interference occurred by peripheral devices.
- 5) To cope with EMI, take measures basically on outputting side.
- 6) If DC is impressed on the liquid crystal display panel, display definition is rapidly deteriorated by the electrochemical reaction that occurs inside the liquid crystal display panel. To eliminate the opportunity of DC impressing, be sure to maintain the AC characteristics of the input signals sent to the LCD Module.

## 11.4 Others

- 1) Liquid crystals solidify under low temperatures (below the storage temperature range) leading to defective orientation or the generation of air bubbles (black or white).  
Air bubbles may also be generated if the LCD module is subjected to a strong shock at a low temperature.
- 2) If the LCD modules have been operating for a long time showing the same display patterns, the display patterns may remain on the screen as ghost images and a slight contrast irregularity may also appear. A normal operating status can be regained by suspending use for some time. It should be noted that this phenomenon does not adversely affect performance reliability.
- 3) To minimize the performance degradation of the LCD modules resulting from destruction caused by static electricity, etc., exercise care to avoid touching the following sections when handling the module:
  - Terminal electrode sections.
  - Part of pattern wiring on TAB, etc.