

SPECIFICATION



YMSC-G128128CDGSWWD

September 27, 2007
Version 1.01



CONTENTS

1.	GERENAL SPECIFICATIONS	3
2.	FEATURES	3
3.	MACHANICAL SPECIFICATIONS	4
4.	ABSOLUTE MAXIMUM RATINGS	4
5.	ELECTRICAL CHARACTERISTICS	4
6.	OPTICAL CHARACTERISTICS	5
7.	TIMING CHARACTERISTICS	6,7
8.	PIN ASSIGNMENT	8
9.	BLOCK DIAGRAM	9
10.	OUTLINE DIMENSIONS	10
11.	ENVIRONMENTAL ABSOLUTE MAXIMUM RATINGS	11
12.	RELIABILITY	11
13.	PRECAUTION FOR USE	12



1. GENERAL SPECIFICATIONS :

1-1 SCOPE:

This specification covers the delivery requirements for the liquid crystal display delivered by YAOYU TECHNOLOGY to Customer .

1-2 PRODUCTS:

Liquid Crystal Display Module (LCM)

1-3 MODULE NAME:

YMSC-G128128CDGSWWD

2. FEATURES :

2-1 MAIN LCD (LARGE)

Item	Standard Value
Display Type	128*128 dots
LCD Type	<input type="checkbox"/> FSTN, BLUE,Transmissive,Negative,Extened TEMP <input type="checkbox"/> FSTN, Transflective,Positive,Extened TEMP <input type="checkbox"/> STN, BLUE,Transmissive,Negative,Extened TEMP <input checked="" type="checkbox"/> STN, GREY,Transflective,Positive,Extened TEMP <input type="checkbox"/> STN, Yellow-GREEN,Positive,Extended TEMP
Drive Pattern	1/64 Duty, 1/9Bias
Viewing Direction	6 O'clock
Backlight Type	<input type="checkbox"/> YELLOW-GREEN LED BOTTOM BL <input checked="" type="checkbox"/> WHITE LED BL <input type="checkbox"/> CCFL WHITE BL
Weight	TBD
Interface	8-bit 6800MPU interface
Driver IC	KS0108

3. MACHANICAL SPECIFICATIONS :

ITEM	STANDARD VALUE	UNIT
DISPLAY FORMAT	128X 128 DOTS	
MODULE DIMENSION	85.5(W) X100.0(H) X 13.0(T)MAX	mm
EFFECTTVE DISPLAY AREA	55.0(W) X55.0(H)	mm
DOT SIZE	0.39(W) X 0.39 (H)	mm
DOT PITCH	0.43W) X 0.43(H)	mm
LCD TYPE	GRAY, STN	
DUTY AND BIAS	1/64 DUTY; 1/9 BIAS	
VIEWING DIRECTION	6:00	
BACK LIGHT	WHITE LED BLD	

4. ABSOLUTE MAXIMUM RATING

ITEM	SYMBOL	CONDITION	STANDARD VALUE			UNIT
			MIN	TYP	MAX	
POWER SUPPLY FOR LOGIC	VDD	Ta=25°C	-0.3	—	7.0	V
INPUT VOLTAGE	VIN	Ta=25°C	-0.3	—	VDD+0.3	V
Module OPERATION TEMPERATURE	TOPR	---	-10	—	+60	°C
Module STORAGE TEMPERATURE	TSTG	---	- 20	—	+70	°C
Storage Humidity	H _D	Ta < 40 °C	-		90	%RH

5. ELECTRICAL CHARACTERISTICS

ITEM	SYMBO L	CONDITIO N	MIN	TYP	MA X	UN IT
Supply Voltage (logic)	Vdd-Vss	-	4.8	5	5.2	V
Supply Voltage (LCD)	Vlcd	Vdd=5V (25°C)	6	-	19	V
Input signal voltage	V-ih	“H” level	0.7Vdd	-	Vdd	V
	V-il	“L” level	0	-	0.8	V
Output signal voltage	V-oh	“H” level	2.4	-	-	V
	V-ol	“L” level	-	0.4	-	V
Supply Current (logic)	Icc	-	0.5	-	2	mA
Supply Current (LCD)	Io	-	-	-	-	mA
Supply Voltage (LED)	V-bl	See note 1	2.9	3.0	3.1	V
Supply Current (LED)	I-bl	See note 1	170	180	200	mA

Note 1: We have set some resistors between the backlight and the backlight power supply “A”.

6. OPTICAL CHARACTERISTICS

(1) DEFINITION OF VIEWING ANGLE

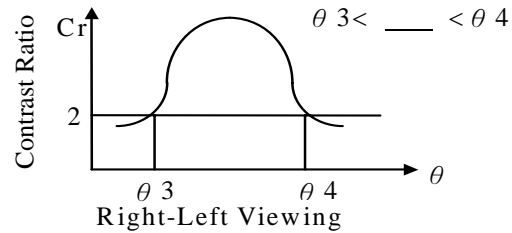
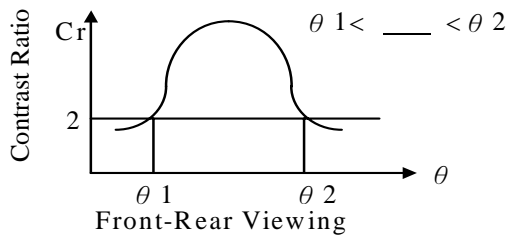
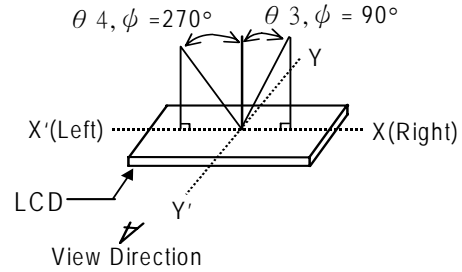
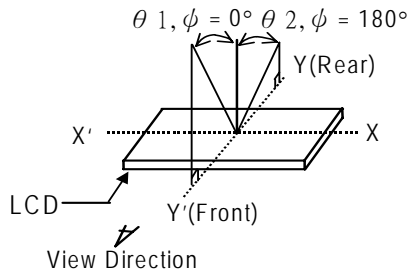

(2) DEFINITION OF CONTRAST

$$C.R = \frac{\text{Brightness of non-selected segment (B2)}}{\text{Brightness of selected segment (B1)}}$$

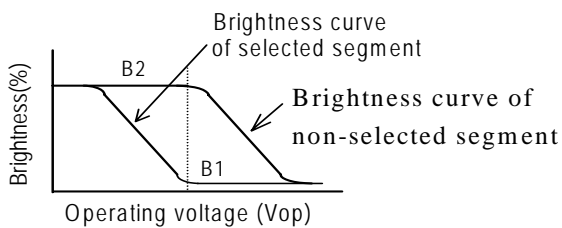

(3) DEFINITION OF RESPONSE

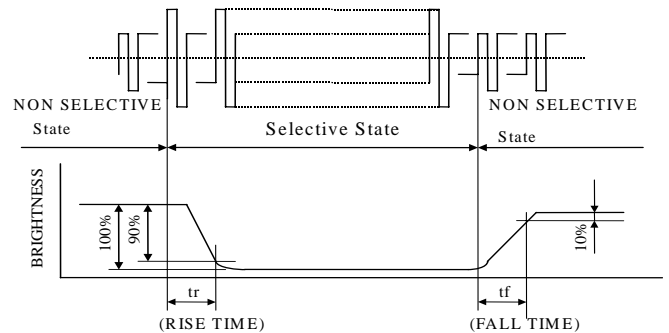

(4) Measuring Instruments For Electro-optical Characteristics

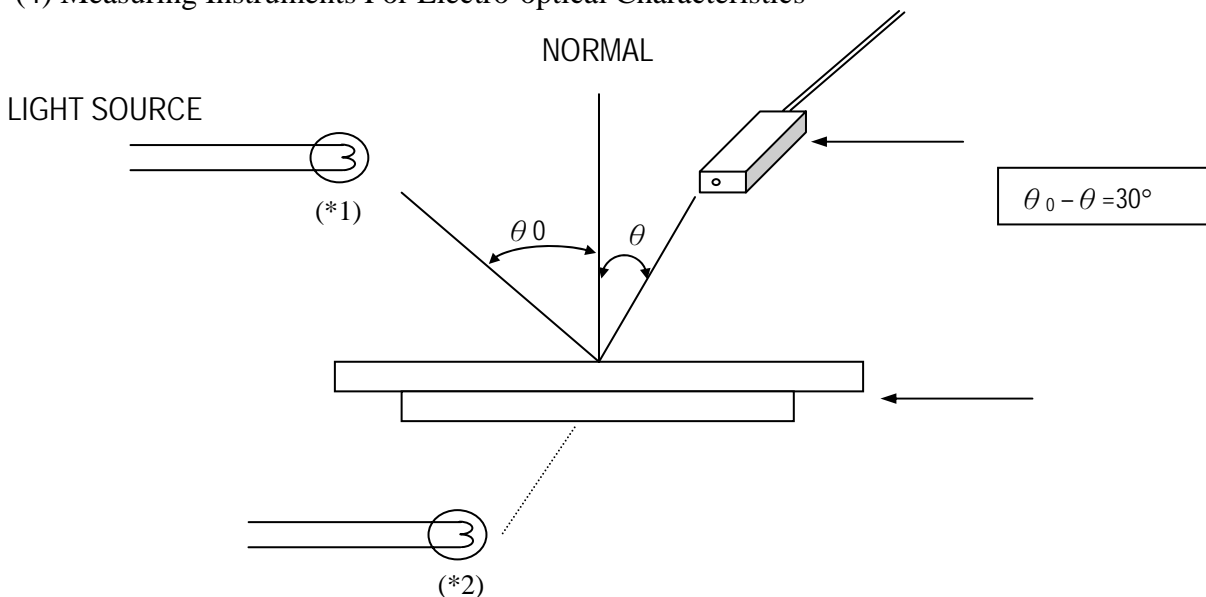

7.0 .TIMING CHARACTERISTICS

AC Characteristics ($V_{DD}=+5V \pm 10\%$, $V_{SS}=0V$, $T_a=-30^{\circ}C \sim +85^{\circ}C$)

1. Clock Timing

Characteristic	Symbol	Min	Typ	Max	Unit
CLK1, CLK2 Cycle Time	t_{CY}	2.5	-	20	μS
CLK1 'LOW' Level Width	t_{WL1}	625	-	-	ns
CLK2 'LOW' Level Width	t_{WL2}	625	-	-	
CLK1 'HIGH' Level Width	t_{WH1}	1875	-	-	
CLK2 'HIGH' Level Width	t_{WH2}	1875	-	-	
CLK1-CLK2 Phase Difference	t_{D12}	625	-	-	
CLK2-CLK1 Phase Difference	t_{D21}	625	-	-	
CLK1, CLK2 Rise Time	t_R	-	-	150	
CLK1, CLK2 Fall Time	t_F	-	-	150	

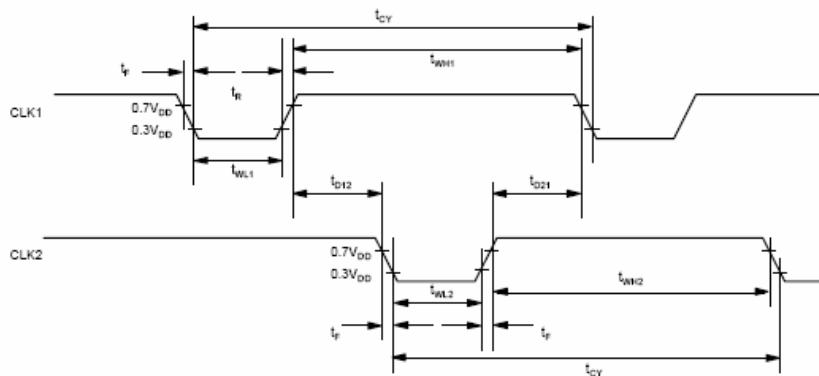

Fig4. External clock waveform



2. Display Control Timing

Characteristic	Symbol	Min	Typ	Max	Unit
FRM Delay Time	t_{DF}	-2	-	+2	us
M Delay Time	t_{DM}	-2	-	+2	us
CL 'LOW' Level Width	t_{WL}	35	-	-	us
CL 'HIGH' Level Width	t_{WH}	35	-	-	us

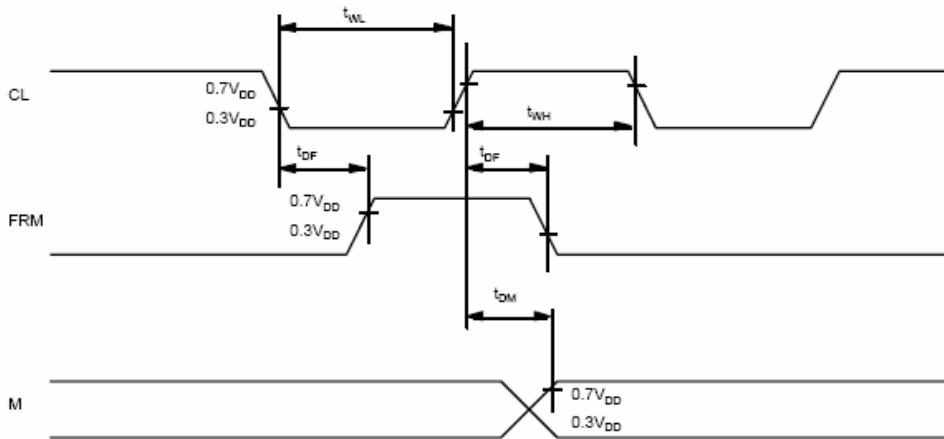

Fig 5. Display control signal waveform



3. MPU Interface

Characteristic	Symbol	Min	Typ	Max	Unit
E Cycle	t_c	1000	-	-	ns
E High Level Width	t_{WH}	450	-	-	ns
E Low Level Width	t_{WL}	450	-	-	ns
E Rise Time	t_R	-	-	25	ns
E Fall Time	t_F	-	-	25	ns
Address Set-Up Time	t_{ASU}	140	-	-	ns
Address Hold Time	t_{AH}	10	-	-	ns
Data Set-Up Time	t_{DSU}	200	-	-	ns
Data Delay Time	t_D	-	-	320	ns
Data Hold Time (Write)	t_{DHW}	10	-	-	ns
Data Hold Time (Read)	t_{DHR}	20	-	-	ns

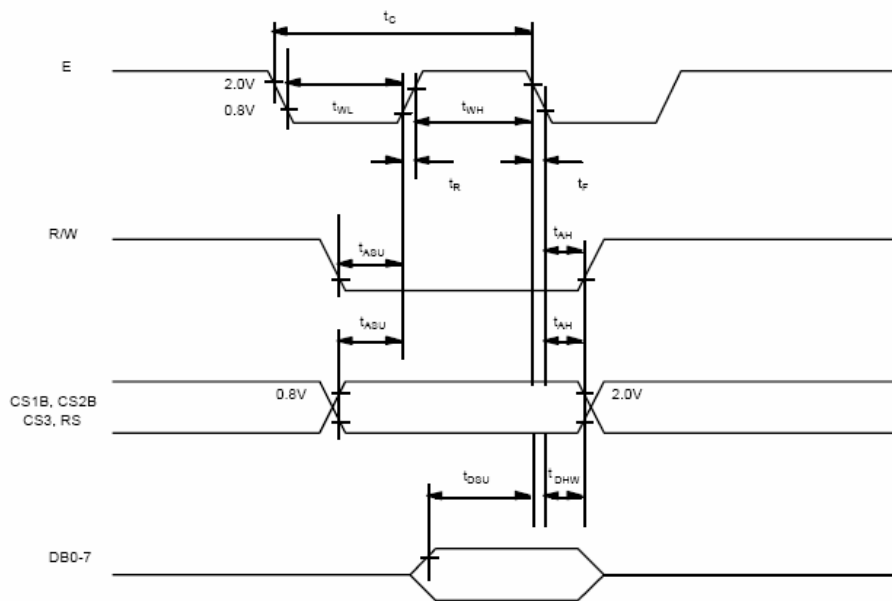

Fig 6. MPU write timing

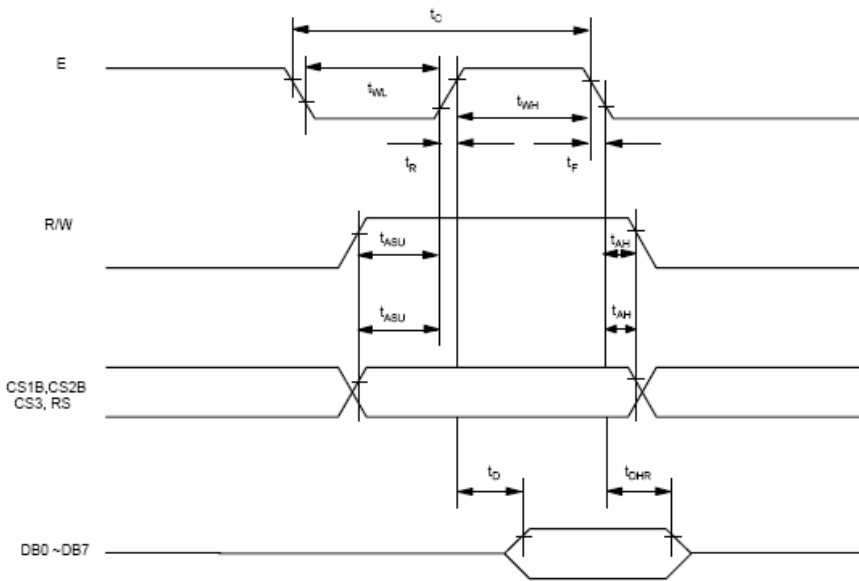

Fig 7. MPU Read timing

8. PIN ASSIGNMENT

PIN	SYMBOL	FUNCTION
1	GND	Power Supply(GND)
2	VDD	Power Supply(+5V)
3	VO	Power Supply for LCD(Contrast Adjust)
4	RS	D/I = "H" DB(0:7):Display RAM Data; D/I = "L" DB(0:7):Instruction Data;
5	R/W	Read or Write RW = "H" :read; RW = "L" :Write
6	E	Enable signal.
7	RET	Reset signal
8~15	DB0~DB7	DATA BUS
16	CS1	Chip selection of U3(Top Left Panel) In order to interface data for input or output,the terminal has to be CS1=H, CS2=L, CS3=L,CS4=L.
17	CS2	Chip selection of U2(Top Right Panel) In order to interface data for input or output,the terminal has to be CS1=L, CS2=H, CS3=L,CS4=L.
18	CS3	Chip selection of U5(DOWN Left Panel) In order to interface data for input or output,the terminal has to be CS1=L, CS2=L, CS3=H,CS4=L.
19	CS4	Chip selection of U4(DOWN Right Panel)



		In order to interface data for input or output, the terminal has to be CS1=L, CS2=L, CS3=L, CS4=H.
20	Vout	Negative Voltage Supply
21	ELK	Power Supply For Backlight(GND)
22	ELA	Power Supply for Backlight +5V

9. BLOCK DIAGRAM

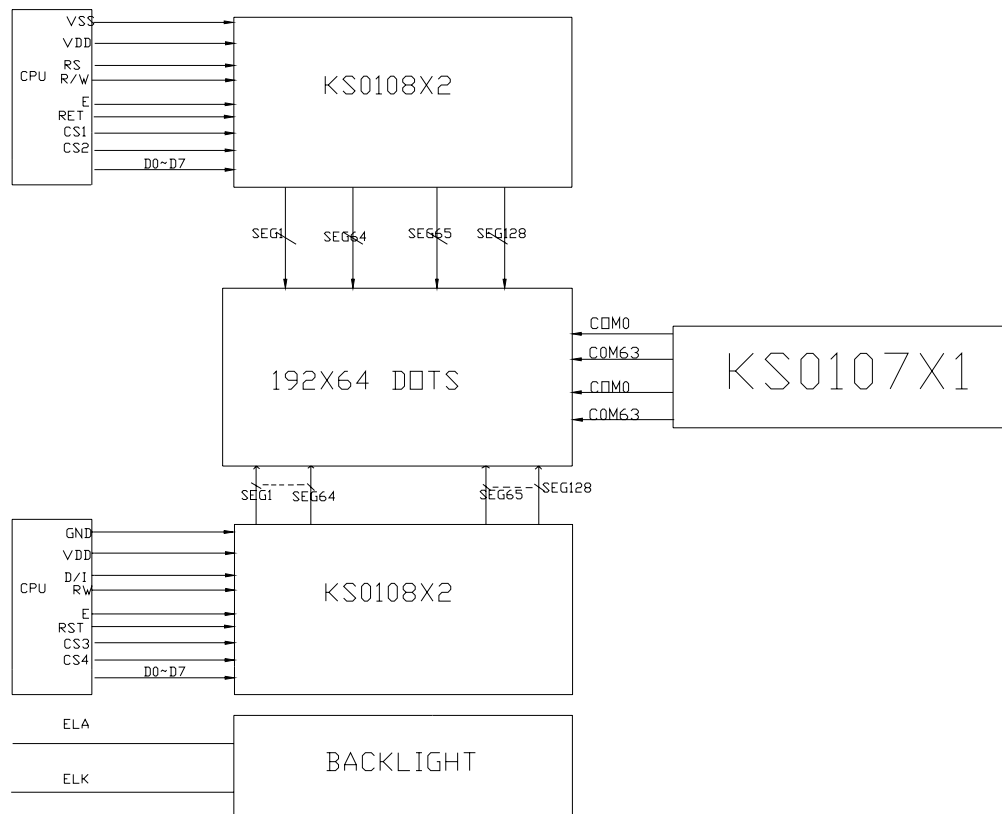

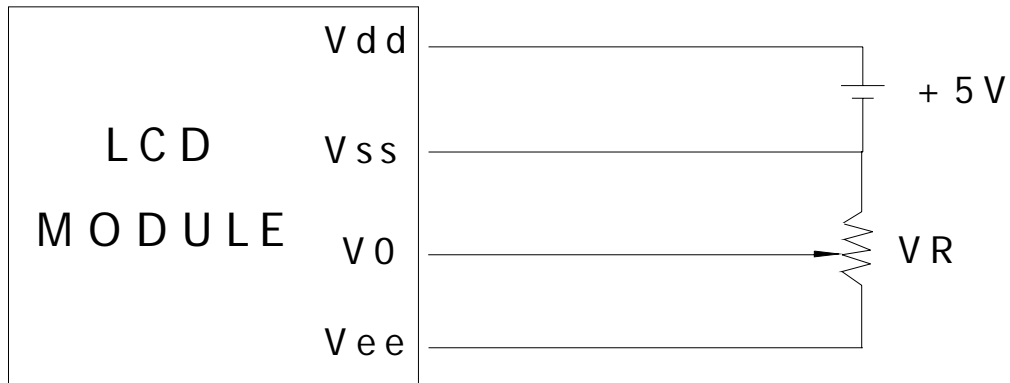

Vdd-V0: LCD Driving Voltage
VR: 10K - 20K

Display Control Instruction:

Please refer to the series of KS0108.

10.OUTLINE DIMENSIONS

11. ENVIRONMENTAL ABSOLUTE MAXIMUM RATINGS

ITEM	SYMBOL	CONDITIONS	CRITERION
OPERATING TEMPERATURE	TOPR	-20°C ~ +70°C	NO DEFECT IN DISPLAYING AND OPERATIONAL FUNCTION
STORAGE TEMPERATURE	TSTG	-30°C ~ +80°C	NO DEFECT IN DISPLAYING AND OPERATIONAL FUNCTION
HUMIDITY	—	See Note	WITHOUT CONDENSATION

12. RELIABILITY
12-1 RELIABILITY TEST

ITEM	CONDITIONS	CRITERION
OPERATING TEMPERATURE	HIGH TEMPERATURE +70°C 240HRS	NO DEFECT IN DISPLAYING AND OPERATIONAL FUNCTION
	LOW TEMPERATURE -20°C 240HRS	
STORAGE TEMPERATURE	HIGH TEMPERATURE +80°C 240HRS	NO DEFECT IN DISPLAYING AND OPERATIONAL FUNCTION
	LOW TEMPERATURE - 30°C 240HRS	
HUMIDITY	40°C 90%RH 240HRS	NO DEFECT IN DISPLAYING AND OPERATIONAL FUNCTION
VIBRATION	<ul style="list-style-type: none"> • Operating Time: thirty minutes exposure for each direction (X,Y,Z) • Sweep Frequency: 10~55Hz (1 min) • Amplitude: 1.5mm 	NO DEFECT IN DISPLAYING AND OPERATIONAL FUNCTION
THERMAL SHOCK	-20°C (30mins) ←→ +70°C (30mins) 10 cycles	NO DEFECT IN DISPLAYING AND OPERATIONAL FUNCTION

*NOTE: TEST CONDITION

(1) TEMPERATURE AND HUMIDITY: IF NO SPECIFICATION, TEMP. SET AT 25±2°C, HUMIDITY SET AT 60±5%RH

(2) OPERATING STATE: SAMPLES SUBJECT TO THE TESTS SHALL BE IN "OPERATING" CONDITION



13. Precaution for Use

The following precautions should be followed, since this module contains precise parts.

- (1) Do not store module for an extended periods of time under the conditions of high temperature and high humidity.
- (2) Avoid using or storing the module in areas that expose it to direct sunlight or ultraviolet rays.
- (3) Use protective finger covers when handling the module to avoid scratching or staining the module.
- (4) Care should be taken not to expose the module to static electricity, because the module contains C-MOS LSI's.
- (5) The LSI is sensitive to light.
The user's product should be designed so that LSI is not exposed to any light during operation.
- (6) During installation, cover the display area with acrylic protection plates to protect the polarizer plate and LCD cells.
- (7) Do not apply any excessive shocks to the module because the module contains sensitive LCD cells.
Do not use a module, which has experienced strong mechanical shock.
- (8) Care should be taken when the power supply turns on as following.
 - (a) Do not apply any input signals before the supplying voltage is applied.
 - (b) Do not turn off the power supply while any input signals are applied.

Caution

- (1) Dangerous. Do not shock glass because glass can break.
- (2) If module breaks, do not touch it directly.
(Glass could stick or cut skin.)
- (3) Do not swallow Liquid Crystal.
(In case of broken LCD panel, do not swallow liquid crystal even if there is no proof that liquid crystal is poisonous.)
- (4) If liquid crystal is exposed to skin, wash the area thoroughly with alcohol or soap.
- (5) When disposing of the product, please observe industrial waste disposal laws in each country and district.
- (6) In case of injury, give immediate treatment and consult with a doctor.
- (7) This product is constructed precisely. Don't disassemble or modify.

※ Neglecting this mark can cause injury to humans and damage to materials